

COMMON COUNCIL
of the
CITY OF SYRACUSE

(10/10)

REGULAR MEETING – OCTOBER 16, 2023

1:00 P.M.

1. *Pledge of Allegiance to the Flag*
2. *Invocation*
3. *Roll Call*
4. *Minutes*
5. *Petitions*
6. *Committee Reports*
7. *Communications*

NEW BUSINESS

BY PRESIDENT HUDSON:

8. *Resolution - Approving the Appointment of Various Persons as Commissioners of Deeds for 2023/2024.*

BY COUNCILOR CALDWELL:

9. *Contract - With Cornell Cooperative Extension of Onondaga County for services that support access to educational programming, such as nutrition, wellness, leadership and gardening for youth, families, adults and senior citizens, on behalf of the Department of Parks, Recreation, & Youth Programs. Cornell Cooperative Extension educators will lead educational sessions in City facilities, as part of afterschool, senior recreation, and summer programs, effective from the date of execution to expire June 30, 2024. There is no cost to the City.*

10. Amend – Ord. #683 (10/11/2022) “Agreement - With Barton & Loguidice, D.P.C. for General Landscape Architectural Services, on behalf of the Department of Parks, Recreation, & Youth Programs, for the period of October 1, 2022-September 30, 2023, with two (2) one-year renewal options with the approval of the Mayor and the Common Council. Total cost not to exceed \$31,250, charged to Account #01.74100.541500.” Amend to change the company name to Collier Engineering & Design CT PC and authorize the first of two (2) one-year renewal options to be effective October 1, 2023 – September 30, 2024. All other terms remain the same.
11. Amend – Ord. #684 (10/11/2022) “Agreement - With Bergmann, Architects, Engineers, Planners, on behalf of the Department of Parks, Recreation, & Youth Programs, for General Landscape Architectural Services, for the period of October 1, 2022-September 30, 2023, with two (2) one-year renewal options with the approval of the Mayor and the Common Council. Total cost not to exceed \$31,250, charged to Account #01.74100.541500.” Amend to authorize the first of two (2) one-year renewal options, effective October 1, 2023 – September 30, 2024. All other terms remain the same.
12. Amend – Ord. #685 (10/11/2022) “Agreement - With Terry Horst Landscape Architecture, PC, for General Landscape Architectural Services, on behalf of the Department of Parks, Recreation, & Youth Programs, for the period of October 1, 2022-September 30, 2023, with two (2) one-year renewal options with the approval of the Mayor and the Common Council. Total cost not to exceed \$31,250, charged to Account #01.74100.541500.” Amend to authorize the first of two (2) one-year renewal options, effective October 1, 2023 – September 30, 2024. All other terms remain the same.
13. Amend – Ord. #686 (10/11/2022) – “Agreement - With QPK Design, LLP, for General Landscape Architectural Services, on behalf of the Department of Parks, Recreation, & Youth Programs, for the period of October 1, 2022-September 30, 2023, with two (2) one-year renewal options with the approval of the Mayor and the Common Council. Total cost not to exceed \$31,250, charged to Account #01.74100.541500.” Amend to authorize the first of two (2) one-year renewal options, effective October 1, 2023 – September 30, 2024. All other terms remain the same.
14. Authorize – Payment for various musical performances at the Holiday Hayride Event at Burnet Park in December 2023, on behalf of the Department of Parks, Recreation & Youth Programs. Total cost not to exceed \$2,000 charged to Account #01.71400.540552.
15. Purchase – w/c/b - Agreement - With Route 80 Quarry Ridge Stables, for Horse-Drawn Wagon Rides at the Annual Holiday Hayrides Event at Burnet Park. This year’s event will be held Friday, December 8th and 15th and Saturday, December 9th and 16th 2023, on behalf of the Department of Parks, Recreation & Youth Programs. Total cost not to exceed \$5,200 to be charged to Account #01.71400.540552.

BY COUNCILOR GREENE:

16. Amend – Ord #775 (11/21/2023), “Authorize - An Exemption Agreement with Rochester’s Cornerstone Group, Ltd Housing Development Fund Corporation aka the Eastwood Heights Housing Development Fund Corporation (the “Corporation”) pursuant to Section 573 and Section 577 Article 11 of the New York Private Housing Finance Law and Section 402 of the New York Not-For-Profit Corporation Law, that involves the property located at 1025 Sunnycrest Road (SBL 027.-09-01.1), commonly known as Eastwood Heights (the “Property”), leased and operated by Syracuse Housing Authority (“SHA”) as a senior housing complex for several decades. The Corporation proposes to lease the Property from SHA after SHA purchased the Property from the City, to renovate the Property, preserving the 49 units, for the period of fifteen (15) years based on 10% of annual gross revenue minus utilities, or \$26,950, whichever is greater.” Amend to increase the renovation from 49 units to 53 units. All other terms remain the same.
17. Authorize - An Exemption Agreement with COR Van Rensselaer Street Company IV, to be known as the Aerie Housing Development Fund Company, Inc. (“the Company”) pursuant to Section 573 and Section 577 Article 11 of the New York Private Housing Finance Law and Section 402 of the New York Not-For-Profit Corporation Law, that involves the property located at 710 Van Rensselaer Street (SBL 117.-01-01.4), currently a vacant lot adjacent to the Inner Harbor, to construct 62 units of affordable housing. The term would be for the period of fifteen (15) years with one (1) fifteen (15) year renewal option with the approval of the Mayor and the Common Council, based on 10% of annual gross revenue minus utilities, or \$34,100, whichever is greater.
18. Correct Tax Rolls – (117 Game Road, to change the assessment roll for tax year 2023/2024) as detailed in Appendix “A.”

BY COUNCILOR PANIAGUA:

19. Agreement - With Aetna Insurance Agency, to provide health and pharmaceutical benefit to all City retirees, effective January 1, 2024, for a period of three (3) years, with two (2) one-year renewal options with the approval of the Mayor and the Common Council. The City will pay an annual rate of \$3,666,666 per year, as detailed in the legislation. Total cost not to exceed \$11,000,000 charged to Account #590601.01.90600.

BY COUNCILOR GETHERS:

20. Accept - A permanent easement from TLSP CODA LLC, the owner of the CODA Apartment Project (399 South Crouse Avenue) along the 300 Block of South Crouse to facilitate the Public Use of a sidewalk, as detailed in Attachment “A.”

21. Amend – Ord. #180 (05/06/2019), “Agreement - With Rothschild Development Corporation for parking in the Madison/Irving Parking Garage as per Schedule “A”. Amend to extend the agreement for a ten (10) year term, commencing on July 1, 2019-June 30, 2029, rates detailed in a revised Schedule “A”. Amend to extend the agreement for a fifteen (15) year term, commencing on July 1, 2029-June 30, 2038, rates detailed in a revised Schedule “A”. All other terms remain the same.
22. Bond Ordinance – Authorizing the issuance and sale of bonds of the City of Syracuse to defray the cost of the 2023/2024 City Owned Building Improvements and Reconstruction. Total amount not to exceed \$600,000.
23. Authorize – The 2023/2024 City Owned Building Improvements and Reconstruction, to complete necessary improvements and reconstruction at City Hall, the Department of Public Works facility, and other city owned buildings, as detailed in the legislation. Total cost not to exceed \$600,000.
24. Amend – Ord. #701 (10/05/2022) “Agreement - With SUNY Upstate Medical University to purchase white road salt from the Department of Public Works for the 2022/2023 winter season for the period of one year, with three (3) one-year renewal options with the approval of the Mayor and the Common Council. The City price is \$44.28 per ton for the 2022/2023 season, plus \$5.00 per ton administrative fee, total price of \$49.28 per ton, to be deposited in Account #417120.01”. Amend to authorize the second of four (4) one-year renewal options and increase the total price to \$54.20 per ton.
25. Amend – Ord. #702 (10/11/2022), “Agreement - With CNY Centro to purchase white road salt from the Department of Public Works for the 2022/2023 winter season for the period of one year, with four (4) one-year renewal options with the approval of the Mayor and the Common Council. The City price is \$44.28 per ton for the 2022/2023 season, plus \$5.00 per ton administrative fee, total price of \$49.28 per ton, to be deposited in Account #417120.01”. Amend to authorize the second of four (4) one-year renewal options and increase the total price to \$54.20 per ton.
26. Amend – Ord. #703 (10/11/2022) “Agreement - With Syracuse Housing Authority to purchase white road salt from the Department of Public Works for the 2022/2023 winter season for the period of one year, with four (4) one-year renewal options with the approval of the Mayor and the Common Council. The City price is \$44.28 per ton for the 2022/2023 season, plus \$5.00 per ton administrative fee, total price of \$49.28 per ton, to be deposited in Account #417120.01”. Amend to authorize the second of four (4) one-year renewal options and increase the total price to \$54.20 per ton.
27. Amend – Ord. #704 (10/11/2022) “Agreement - With Onondaga County relative to the use of the City of Syracuse D.P.W. Fuel Facility for the period of one year, commencing on October 14, 2022, with one (1) one-year renewal option. at the City’s cost, plus \$.06 per gallon for maintenance and 5% administrative charge, to be deposited in Account #423010.01”. Amend to authorize the final one-year renewal option, effective October 14, 2023 – October 13, 2024.

28. Amend – Ord. #705 (10/11/2022), “Agreement - With the Syracuse City School District relative to the use of the City of Syracuse D.P.W. Fuel Facility for the period of one year, commencing on October 14, 2022, with one (1) one-year renewal option, with the approval of the Mayor and the Common Council. Fuel will be charged at the City’s cost, including compressed natural gas, plus an additional fee of \$.06 per gallon for maintenance and (5%) administrative charge for vehicle key and personnel I.D. numbers, to be deposited in Account #549100.01.51320.” Amend to authorize final one-year renewal option, effective October 14, 2023 – October 13, 2024.
29. Amend – Ord. #706 (10/11/202) “Agreement - With the Syracuse Housing Authority relative to the use of the City of Syracuse D.P.W. Fuel Facility for the period of one year, commencing on October 14, 2022, with one (1) one-year renewal option, with the approval of the Mayor and the Common Council. Fuel will be charged at the City’s cost, plus an additional fee of \$.06 per gallon for maintenance and 5% administrative charge for vehicle key and personnel I.D. numbers, to be deposited in Account #417120.01.” Amend to authorize the final one-year renewal option, effective October 14, 2023 – October 13, 2024.
30. Agreement – With Barton & Loguidice, D.P.C., for the Scoping & Preliminary Design Service Fee for the Erie Boulevard West Pedestrian and Bike Improvements Project, PIN 3950.80, on behalf of the Department of Engineering. Total cost not to exceed \$296,000, to be paid on a time and expense basis for all services. The project is funded with 80% federal funds and 20% of local funds (Ord. #834-2022), from Capital Account #599807.07.80405.700395080.
31. Agreement – With Barton & Loguidice, D.P.C., for the Scoping & Preliminary Design Service Fee for the Kirk Park Pedestrian Bride Replacement Project, PIN 3950.79, on behalf of the Department of Engineering. Total cost not to exceed \$183,750, to be paid on a time and expense basis for all services. The project is funded with 80% federal funds and 20% of local funds (Ord. #831-2022), from Capital Account #599807.07.80405.700395079.
32. Bond Ordinance – Authorizing the issuance and sale of bonds of the City of Syracuse to defray the cost of the Scoping, Preliminary & Detailed Design Phases of the Rt. 175 over Onondaga Creek Bridge Rehabilitation Project, PIN 3757.19. Total amount not to exceed \$315,000.
33. Agreement – With NYS DOT for the Scoping, Preliminary & Detailed Design Phases of the Rt. 175 over Onondaga Creek Bridge Rehabilitation Project, PIN 3757.19 (location also known as South Avenue over Onondaga Creek at Kirk Park), on behalf of the Department of Engineering. The City will incur all initial costs for this project with subsequent 95% (\$299,250) federal reimbursement through TIP. The local share will be 5% (\$15,750). Total amount not to exceed \$315,000.

34. *Authorize – The Scoping, Preliminary & Detailed Design Phases of the Rt. 175 over Onondaga Creek Bridge Rehabilitation Project, PIN 3757.19 (location also known as South Avenue over Onondaga Creek at Kirk Park), on behalf of the Department of Engineering. The City will incur all initial costs for this project with subsequent 95% (\$299,250) federal reimbursement through TIP. The local share will be 5% (\$15,750). Total amount not to exceed \$315,000.*
35. *Authorize – Temporary Access Agreement with Onondaga County to close South Warren Street between South Salina Street (north of the Salvation Army driveway) to East Adams Street and Billings Park, to be used as a staging area for the STEAM School Construction Project, as detailed in the legislation.*

BY COUNCILOR HOGAN:

36. *Amend – Ord. #728 (10/24/2022) “Agreement – With Upstate Minority Economic Alliance (UMEA), to implement a Business Growth Accelerator (BGA) Program, to deliver a business development program for thirty (30) current NYS-certified MWBEs. The program will design, enroll and deliver training and business growth plan development to build capacity for contracting opportunities on NYS-funded construction projects, as detailed in the contract, for a twelve (12) month period. The grant in the amount of \$70,000 was awarded by NYS Empire State Development for Central NY and Mohawk Valley region. Administered by NBD Division of Business Development. The Mayor waived the RFP process.” Amend to extend the contract through March 31, 2024. All other terms remain the same.*
37. *Amend – Ord. #729 (10/24/2022) “Agreement – With OMNI Procurement Solutions, LLC. (OMNI), to implement a Business Growth Accelerator (BGA) Program, to deliver a business development program for thirty (30) current NYS-certified MWBEs. The program will design, enroll and deliver training and business growth plan development to build capacity for contracting opportunities on NYS-funded construction projects, as detailed in the contract, for a twelve (12) month period. The grant in the amount of \$202,000 was awarded by NYS Empire State Development for Central NY and Mohawk Valley regions. Administered by NBD Division of Business Development. The Mayor waived the RFP process.” Amend to extend the contract through March 31, 2024. All other terms remain the same.*
38. *Amend – Ord. #368 (06/05/2023) “Authorize – The Department of Neighborhood & Business Development, to purchase furniture and other necessary materials, from RightPrice Companies, for the new office space at One Park Place. Total cost not to exceed \$800,000, details outlined in the attachment”. Ament to add, Sedgewick Business Interiors, Graninger, and Baruch Park Place, LLC, as authorized vendors, to be charged to Account #07.64205.706420523.599807.*

BY COUNCILOR MAJOK:

39. *Application & Agreement – To and with the New York State Division of Homeland Security and Emergency Services, State Homeland Security Program (SHSP) for the 2021 Bomb Squad Initiative Grant, in an amount not to exceed \$91,666 to enhance Bomb Squad Capabilities in Central New York. No local match required.*
40. *Application & Agreement – To and with the New York State Division of Homeland Security and Emergency Services, State Homeland Security Program (SHSP) for the 2022 Bomb Squad Initiative Grant in an amount not to exceed \$83,333, to enhance Bomb Squad Capabilities in Central New York. No local match required.*
41. *Application & Agreement – To and with the New York State Division of Homeland Security and Emergency Services, for the 2021 Technical Rescue & Urban Search and Rescue Grant (USAR21), for the Department of Fire, in an amount not to exceed \$75,000, for overtime and backfill while attending training. No local match required.*
42. *Application & Agreement – To and with the New York State Division of Homeland Security and Emergency Services (SHSP) for the 2021 Critical Infrastructure Grant Program, in an amount not to exceed \$50,000, to be used by the Police and Fire Departments, to purchase equipment for use as detailed in the legislation. No local match is required.*
43. *Application & Agreement – To and with the New York State Division of Homeland Security and Emergency Services, State Homeland Security Program (SHSP) for the 2021 Tactical Team Targeted Grant Program, in an amount not to exceed \$75,000 to uses by the Police Department for equipment purchases for the SWAT Team. No local match required.*
44. *Application & Agreement – To and with the New York State Division of Homeland Security and Emergency Services (SHSP) for the 2021 Cyber Security Grant Program, in an amount not to exceed \$50,000, to be used by the Police Department for Security Training Awareness for all users and to purchase three (3) back up servers. No local match is required.*

BY COUNCILOR ALLEN:

45. *Approve – An installation of an Honorary Street Sign in recognition of Michael Yorton, whose unique vision made him a legendary figure in the City of Syracuse. Yorton operated the Blue Tusk in Center Armory with his father, Tim, and other family members from 1992 until 2022. Blue Tusk won many accolades over the years. In 2008, national magazine “All About Beer” ranked the Blue Tusk No. 48 in its list of “Top 125 Places in the world to have a beer”, ahead of bars in London, Dublin, Munich, and New York City. Yorton is remembered for creating his own community and making many people’s lives more enjoyable.*

46. *Permission – To Acropolis Center LLC, owner of the property located at 333 South Salina Street & East Jefferson Steet, for four (4) concrete bollards that will encroach approximately 2'6" into the Bank Alley right-of-way.*
47. *Permission – To Scott Butler, representing Andrea Goyette, owner of the property at 690 Glencove Road, for stone steps that will encroach approximately 3'6" into the Glencove Road right-of-way.*
48. *Permission – To Henry & Karen Zuranski, owners of the property located at 202 Leavenworth Avenue, for an existing parking area which encroaches approximately 45' into the Leavenworth Avenue right-of-way.*

(SUPPLEMENTAL AGENDA – OCTOBER 16, 2023)
WAIVER OF THE RULES REQUIRED TO INTRODUCE:

BY COUNCILOR HOGAN:

49. *Resolution – In recognition of the Polish Community and the significant contributions they made in the City of Syracuse.*

ORDINANCE AUTHORIZING AN AGREEMENT WITH CORNELL COOPERATIVE EXTENSION OF ONONDAGA COUNTY TO PROVIDE ACCESS TO FREE EDUCATIONAL PROGRAMS RELATIVE TO NUTRITION, WELLNESS, LEADERSHIP AND GARDENING FOR YOUTH, FAMILIES, ADULTS AND SENIOR CITIZENS AT CITY FACILITIES ON BEHALF OF THE DEPARTMENT OF PARKS, RECREATION AND YOUTH PROGRAMS

BE IT ORDAINED, subject to the approval of the Mayor, that the Mayor be and he is hereby authorized to enter into an agreement with Cornell Cooperative Extension of Onondaga County to provide access to free educational programming relative to nutrition, wellness, leadership, and gardening for youth, families, adults, and senior citizens at City Facilities on behalf of the Department of Parks, Recreation and Youth Programs; and

BE IT FURTHER ORDAINED, that pursuant to the terms and conditions of the agreement authorized herein Cornell Cooperative Extension of Onondaga County will lead educational sessions in City facilities as part of the Department of Parks, Recreation and Youth Programs After School Recreation Programs, Senior Recreation Programs, and Summer Recreation Programming; and

BE IT FURTHER ORDAINED, that this Agreement shall be effective from the date of execution through June 30, 2024 and the services shall be provided at no cost to the City; and

BE IT FURTHER ORDAINED, that there shall be no cost to the City for the services provided pursuant to said agreement; and

BE IT FURTHER ORDAINED, that said agreement shall contain such other terms and conditions as the Corporation Counsel shall deem in the best interest of the City of Syracuse.

9



DEPARTMENT OF PARKS, RECREATION & YOUTH PROGRAMS

CITY OF SYRACUSE, MAYOR BEN WALSH

Tony Williams
Commissioner

September 29, 2023

Chris Abbott
Deputy Commissioner

Patricia McBride
City Clerk
231 City Hall
Syracuse, NY 13202

RE: REQUEST FOR LEGISLATION

Dear Ms. McBride,

Please place on the agenda for the next meeting of the Common Council the necessary legislation to authorize the Mayor, on behalf of the City of Syracuse, to enter into an agreement with Cornell Cooperative Extension of Onondaga County, to support access to educational programming in such areas as nutrition, wellness, leadership and gardening for youth and families, adults and senior citizens.

As part of this agreement, educators from Cornell Cooperative Extension will lead educational sessions in City facilities as part of after school and senior recreation programs, as well as summer recreation programming managed by the Department of Parks, Recreation, and Youth Programs.

The Agreement shall be considered effective from the date signatures are affixed to the Letter of Agreement, through June 30, 2024. There is no cost for the services under this agreement.

Sincerely,

Tony Williams
Commissioner

Syracuse Department
of Parks, Recreation
& Youth Programs
412 Spencer Street
Syracuse, N.Y. 13204

Office 315 473 4330
Fax 315 428 8513

www.syrgov.net

4



OFFICE OF MANAGEMENT & BUDGET

CITY OF SYRACUSE, MAYOR BEN WALSH

Timothy M. Rudd
Director

Julie Castellitto
Assistant Director

TO: Mayor Ben Walsh
FROM: Julie Castellitto, Assistant Director of Management & Budget 
DATE: October 2, 2023
SUBJECT: Agreement – Cornell Cooperative Extension of Onondaga County

On behalf of the Department of Parks, Recreation & Youth Programs, I am requesting the City of Syracuse enter into an agreement with Cornell Cooperative Extension of Onondaga County, to support access to educational programming in such areas as nutrition, wellness, leadership and gardening for youth and families, adults and senior citizens.

As part of the agreement, educators from Cornell Cooperative Extension will lead educational sessions in City facilities as part of after school and senior recreation programs, as well as summer recreation programming managed by the Department of Parks, Recreation, and Youth Programs.

The agreement shall be considered effective from the date signatures are affixed to the letter of agreement through June 30, 2024. There is no cost for the services under this agreement.

If you agree to enter into this agreement, please indicate by signing below and returning this memo to me so that I may forward a copy to the Common Council along with the legislation request for the next Common Council Meeting.

Thank you for your attention regarding this matter.



Mayor Ben Walsh
City of Syracuse, New York

10/4/23

Date

Office of Management
and Budget
233 E Washington St
Room 213
Syracuse, N.Y. 13202

Office 315 448-8252
Fax 315 448-8116

www.syr.gov.net

Ordinance No.

2023

ORDINANCE AMENDING ORDINANCE NO. 683-2022 AUTHORIZING CONTRACT WITH BARTON & LOGUIDICE, D.P.C. RELATIVE TO PROVIDING GENERAL LANDSCAPE ARCHITECTURAL SERVICES FOR THE DEPARTMENT OF PARKS, RECREATION, AND YOUTH PROGRAMS

BE IT ORDAINED, that Ordinance No. 683-2022 is hereby amended to read as follows:

WHEREAS, Section 5-205-A of the Charter of the City of Syracuse, as amended, provides the Mayor shall "award contracts for professional services subject to the approval of the Common Council"; and

WHEREAS, a Request for Proposal (REP) was conducted for General Landscape Architectural Services and the RFP Committee recommended that Barton & Loguidice, D.P.C. be awarded the contract; and

WHEREAS, the Mayor has approved the retention of Barton & Loguidice, D.P.C., under the following terms:

- (1) Barton & Loguidice, D.P.C. shall provide general landscape architectural services for the Department of Parks, Recreation, and Youth Programs on an as-needed basis;
- (2) The City shall pay Barton & Loguidice, D.P.C. an amount not to exceed \$31,250.00 for all services to be provided under this agreement;
- (3) The City does not guarantee any minimum level of work orders to be issued as all work done under the agreement;
- (4) The Agreement shall be for a one (1) year term effective as of October 1, 2022 through September 30, 2023, with the option for two (2) one (1) year extension periods subject to the approval of the Mayor and Common Council; and
- (5) The Agreement is hereby extended for the first one (1) year renewal period to be effective as of October 1, 2023 through September 30, 2024 at a cost not to exceed \$31,250.00 for all services to be provided under the amended Agreement.

;

NOW, THEREFORE,

BE IT ORDAINED, that the Mayor, on behalf of the City of Syracuse, be and he hereby is authorized to execute such amended contract, as hereinabove stated, subject to the approval of the Corporation Counsel as to terms, form and execution; and

BE IT FURTHER ORDAINED, that all costs associated with this amended agreement shall be charged to Budget Account # 01.74100.541500 or another appropriate account a designated by the Commissioner of Finance.

_____ = new material

DRAFT

**ORDINANCE AMENDING ORDINANCE NO.
684-2022 AUTHORIZING CONTRACT WITH
BERGMANN, ARCHITECTS, ENGINEERS,
LANDSCAPE ARCHITECTS & SURVEYORS,
D.P.C. RELATIVE TO PROVIDING GENERAL
LANDSCAPE ARCHITECTURAL SERVICES
FOR THE DEPARTMENT OF PARKS,
RECREATION, AND YOUTH PROGRAMS**

BE IT ORDAINED, that Ordinance No. 684-2022 is hereby amended to read as follows:

WHEREAS, Section 5-205-A of the Charter of the City of Syracuse, as amended, provides the Mayor shall "award contracts for professional services subject to the approval of the Common Council"; and

WHEREAS, a Request for Proposal (REP) was conducted for General Landscape Architectural Services and the RFP Committee recommended that Bergmann, Architects, Engineers, Landscape Architects & Surveyors, D.P.C. (now also operating under the name Collier Engineering & Design CT PC) be awarded the contract; and

WHEREAS, the Mayor has approved the retention of Bergmann, Architects, Engineers, Landscape Architects & Surveyors, D.P.C. (now also operating under the name Collier Engineering & Design CT PC), under the following terms:

- (1) Bergmann, Architects, Engineers, Landscape Architects & Surveyors, D.P.C. (now also operating under the name Collier Engineering & Design CT PC) shall provide general landscape architectural services for the Department of Parks, Recreation, and Youth Programs on an as-needed basis;
- (2) The City shall pay Bergmann, Architects, Engineers, Landscape Architects & Surveyors, D.P.C. (now also operating under the name Collier Engineering & Design CT PC) an amount not to exceed \$31,250.00 for all services under this agreement.
- (3) The City does not guarantee any minimum level of work orders to be issued as all work done under the agreement;
- (4) This Agreement shall be for the period of October 1, 2022 through September 30, 2023, with the option for two (2) one (1) year extension period subject to the approval of the Mayor and Common Council; and

(5) The Agreement is hereby extended for the first one (1) year renewal period to be effective as of October 1, 2023 through September 30, 2024 at a cost not to exceed \$31,250.00 for all services to be provided under the amended Agreement.

NOW, THEREFORE,

BE IT ORDAINED, that the Mayor, on behalf of the City of Syracuse, be and he hereby is authorized to execute such amended contract, as hereinabove stated, subject to the approval of the Corporation Counsel as to terms, form and execution; and

BE IT FURTHER ORDAINED, that all costs associated with this amended agreement shall be charged to Budget Account # 01.74100.541500 or another appropriate account as designated by the Commissioner of Finance.

_____ = new material

DRAFT

**ORDINANCE AMENDING ORDINANCE NO.
685-2022 AUTHORIZING CONTRACT WITH
TERRY HORST LANDSCAPE
ARCHITECTURE, PC RELATIVE TO
PROVIDING GENERAL LANDSCAPE
ARCHITECTURAL SERVICES FOR THE
DEPARTMENT OF PARKS, RECREATION,
AND YOUTH PROGRAMS**

BE IT ORDAINED, that Ordinance No. 685-2022 is hereby amended to read as follows:

WHEREAS, Section 5-205-A of the Charter of the City of Syracuse, as amended, provides the Mayor shall "award contracts for professional services subject to the approval of the Common Council"; and

WHEREAS, a Request for Proposal (RFP) was conducted for General Landscape Architectural Services and the RFP Committee recommended that Terry Horst Landscape Architecture, PC be awarded the contract; and

WHEREAS, the Mayor has approved the retention of Terry Horst Landscape Architecture, PC, under the following terms:

- (1) Terry Horst Landscape Architecture, PC shall provide general landscape architectural services for the Department of Parks, Recreation, and Youth Programs on an as needed basis;
- (2) The City shall pay Terry Horst Landscape Architecture, PC an amount not to exceed \$31,250.00 for all services under this agreement;
- (3) The City does not guarantee any minimum level of work orders to be issued as all work done under the agreement;
- (4) The Agreement shall be for the period of October 1, 2022 through September 30, 2023, with the option for two (2) one (1) year extension periods subject to the approval of the Mayor and Common Council; and
- (5) The Agreement is hereby extended for the first one (1) year renewal period to be effective as of October 1, 2023 through September 30, 2024 at a cost not to exceed \$31,250.00 for all services to be provided under the amended Agreement.

NOW, THEREFORE,

BE IT ORDAINED, that the Mayor, on behalf of the City of Syracuse, be and he hereby is authorized to execute such amended contract, as hereinabove stated, subject to the approval of the Corporation Counsel as to terms, form and execution; and

BE IT FURTHER ORDAINED, that all costs associated with this amended agreement shall be charged to Budget Account # 01.74100.541500 or another appropriate account as designated by the Commissioner of Finance.

_____ = new material

DRAFT

ORDINANCE AMENDING ORDINANCE NO. 686-2022 AUTHORIZING CONTRACT WITH QPK DESIGN, LLP RELATIVE TO PROVIDING GENERAL LANDSCAPE ARCHITECTURAL SERVICES FOR THE DEPARTMENT OF PARKS, RECREATION, AND YOUTH PROGRAMS

BE IT ORDAINED, that Ordinance No. 686-2022 is hereby amended to read as follows:

WHEREAS, Section 5-205-A of the Charter of the City of Syracuse, as amended, provides the Mayor shall "award contracts for professional services subject to the approval of the Common Council"; and

WHEREAS, a Request for Proposal (RFP) was conducted for General Landscape Architectural Services and the RFP Committee recommended that QPK Design, LLP be awarded the contract; and

WHEREAS, the Mayor has approved the retention of QPK Design, LLP, under the following terms:

- (1) QPK Design, LLP shall provide general landscape architectural services for the Department of Parks, Recreation, and Youth Programs on an as needed basis;
- (2) The City shall pay QPK Design, LLP an amount not to exceed \$31,250.00 for all services under this agreement;
- (3) The City does not guarantee any minimum level of work orders to be issued as all work done under the agreement;
- (4) This Agreement shall be for the period of October 1, 2022 through September 30, 2023, with the option for two (2) one (1) year extension periods subject to the approval of the Mayor and Common Council; and
- (5) The Agreement is hereby extended for the first one (1) year renewal period to be effective as of October 1, 2023 through September 30, 2024 at a cost not to exceed \$31,250.00 for all services to be provided under the amended Agreement.

NOW, THEREFORE,

BE IT ORDAINED, that the Mayor, on behalf of the City of Syracuse, be and he hereby is authorized to execute such amended contract, as hereinabove stated, subject to the approval of the Corporation Counsel as to terms, form and execution; and

BE IT FURTHER ORDAINED, that all costs associated with this amended agreement shall be charged to Budget Account # 01.74100.541500 or another appropriate account as designated by the Commissioner of Finance

DRAFT



10-13

OFFICE OF MANAGEMENT & BUDGET

CITY OF SYRACUSE, MAYOR BEN WALSH

October 4, 2023

Timothy M. Rudd
Director

Julie Castellitto
Assistant Director

Ms. Patricia McBride
City Clerk
City Hall
Syracuse, New York

RE: Request for Legislation

Dear Ms. McBride:

On behalf of the Department of Parks, Recreation and Youth Programs, please prepare legislation for the next scheduled Common Council meeting to amend Ordinance #683-2022, 684-2022, 685-2022, 686-2022 and extend the agreements with the following companies for RFP #23-008: General Landscape Architectural Services for the City of Syracuse Department of Parks, Recreation, and Youth Programs.

1. Collier Engineering & Design CT PC, formerly known as Barton & Loguidice, D.P.C.
2. Bergmann, Architects Engineers, Planners
3. Terry Horst Landscape Architecture, PC
4. QPK Design, Architecture, Engineering, Site Planning

The original agreement was for a period of 12 months (from October 1, 2022 to September 30, 2023) with the option of two one-year contract extensions from October 1, 2023 to September 30, 2024 and October 1, 2024 to September 30, 2025. The Department of Parks, Recreation & Youth Programs would like to utilize the first extension from October 1, 2023 to September 30, 2024. Project work orders will be requested by the Commissioner of the Department of Parks, Recreation, & Youth Programs, or their designee.

Office of Management and Budget
233 E Washington St
Room 213
Syracuse, N.Y. 13202

All costs are not to exceed \$125,000.00 per fiscal year, or \$31,250 per contracted Professional Service, where all expenditures will be charged to account 01.71400.541500 or otherwise determined to fulfill work order obligations.

Office 315 448-8252
Fax 315 448-8116

www.syr.gov.net

Sincerely,

Julie Castellitto
Assistant Director of Management and Budget



OFFICE OF MANAGEMENT & BUDGET

CITY OF SYRACUSE, MAYOR BEN WALSH

Timothy M. Rudd
Director

Julie Castellitto
Assistant Director

TO: Mayor Ben Walsh

FROM: Julie Castellitto, Assistant Director of Management & Budget 

DATE: October 4, 2023

SUBJECT: Amend Agreement – Collier Engineering & Design, Bergmann (formerly known as Barton & Loguidice), Architects Engineers, Planners, Terry Horst Landscape and QPK Design, Architecture, Engineering, Site Planning

On behalf of the Department of Parks, Recreation & Youth Programs, I am requesting the City of Syracuse amend Ordinance #683-2022, 684-2022, 685-2022, 686-2022 and extend the agreements with the following companies for RFP #23-008: General Landscape Architectural Services for the City of Syracuse Department of Parks, Recreation, and Youth Programs.

1. Collier Engineering & Design CT PC, formerly known as Barton & Loguidice, D.P.C.
2. Bergmann, Architects Engineers, Planners
3. Terry Horst Landscape Architecture, PC
4. QPK Design, Architecture, Engineering, Site Planning

The original agreement was for a period of 12 months (from October 1, 2022 to September 30, 2023) with the option of two one-year contract extensions from October 1, 2023 to September 30, 2024 and October 1, 2024 to September 30, 2025. The Department of Parks, Recreation & Youth Programs would like to utilize the first extension from October 1, 2023 to September 30, 2024. Project work orders will be requested by the Commissioner of the Department of Parks, Recreation, & Youth Programs, or their designee.

All costs are not to exceed \$125,000.00 per fiscal year, or \$31,250 per contracted Professional Service, where all expenditures will be charged to account 01.71400.541500 or otherwise determined to fulfill work order obligations.

If you agree to enter into this agreement, please indicate by signing below and returning this memo to me so that I may forward a copy to the Common Council along with the legislation request for the next Common Council Meeting.

Thank you for your attention regarding this matter.

Office of Management
and Budget
233 E Washington St
Room 213
Syracuse, N.Y. 13202

Office 315 448-8252
Fax 315 448-8116

www.syr.gov.net

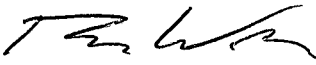

 Mayor Ben Walsh
 City of Syracuse, New York

10/4/23

 Date



DEPARTMENT OF PARKS, RECREATION & YOUTH PROGRAMS

CITY OF SYRACUSE, MAYOR BEN WALSH

September 28, 2023

Tony Williams
Commissioner

Chris Abbott
Deputy Commissioner

Mr. Timothy Rudd
Director of Budget
213 City Hall
Syracuse, NY 13202

RE: Request for Legislation – Landscape Architectural Contract Services Renewal 2023

Dear Mr. Rudd:

Please prepare legislation for the next scheduled Common Council meeting to amend Ordinance #683-2022, 684-2022, 685-2022, 686-2022 and extend the agreements with the following companies for RFP #23-008: General Landscape Architectural Services for the City of Syracuse Department of Parks, Recreation, and Youth Programs.

1. Collier Engineering & Design CT PC, formerly known as Barton & Loguidice, D.P.C.
2. Bergmann, Architects Engineers, Planners
3. Terry Horst Landscape Architecture, PC
4. QPK Design, Architecture, Engineering, Site Planning

The original agreement was for a period of 12 months (from October 1, 2022 to September 30, 2023) with the option of two one-year contract extensions from October 1, 2023 to September 30, 2024 and October 1, 2024 to September 30, 2025. The Department of Parks, Recreation & Youth Programs would like to utilize the first extension from October 1, 2023 to September 30, 2024. Project work orders will be requested by the Commissioner of the Department of Parks, Recreation, & Youth Programs, or their designee.

All costs are not to exceed \$125,000.00 per fiscal year, or \$31,250 per contracted Professional Service, where all expenditures will be charged to account 01.71400.541500 or otherwise determined to fulfill work order obligations.

Sincerely,

Tony Williams
Parks Department Commissioner

Syracuse Department
of Parks, Recreation
& Youth Programs
412 Spencer Street
Syracuse, N.Y. 13204

Office 315 473 4330
Fax 315 428 8513

www.syr.gov

Ordinance No.

2023

**ORDINANCE AUTHORIZING PAYMENT TO
VARIOUS PERFORMERS FOR SERVICES
RELATIVE TO MUSICAL PERFORMANCES
FOR THE DEPARTMENT OF PARKS,
RECREATION AND YOUTH PROGRAMS
HOLIDAY HAYRIDE EVENTS AT BURNET
PARK**

BE IT ORDAINED, that the Commissioner of Finance be and he is hereby authorized to issue warrants to cover costs associated with musical performances for the Department of Parks, Recreation and Youth Programs Holiday Hayride Events to be held on December 8, December 9, December 15, and December 16, 2023 at Burnet Park; and

BE IT FURTHER ORDAINED, that the total cost for all services related to the aforementioned musical performances shall not exceed \$2,000.00 and said payments shall be charged to Recreation Account #01.71400.540552 or another appropriate account as designated by the Commissioner of Finance.

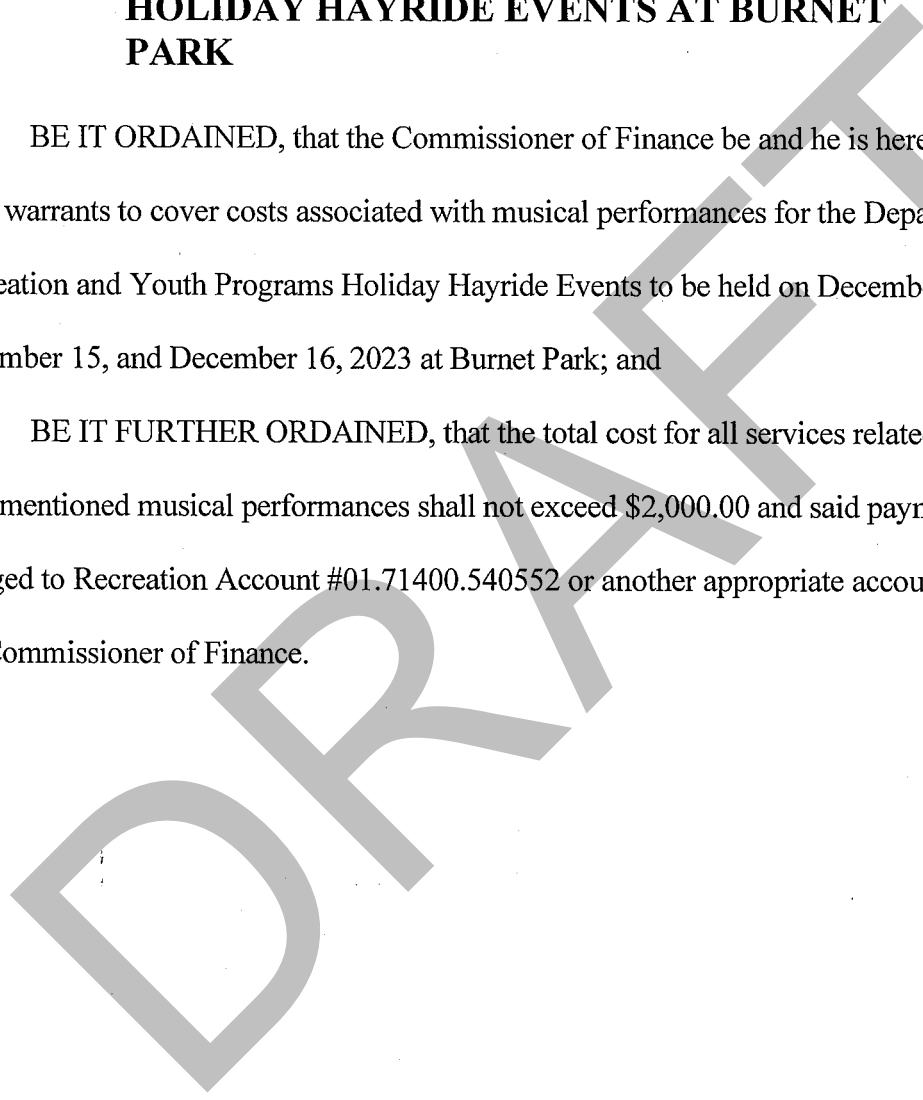

H



DEPARTMENT OF PARKS, RECREATION & YOUTH PROGRAMS

CITY OF SYRACUSE, MAYOR BEN WALSH

Tony Williams
Commissioner

September 28, 2023

Chris Abbott
Deputy Commissioner

Patricia McBride
City Clerk
231 City Hall
Syracuse, NY 13202

RE: REQUEST FOR LEGISLATION

Dear Ms. McBride,

Please prepare legislation for the next Common Council meeting to allow the Department of Parks, Recreation and Youth Programs to authorize payments, at a cost not to exceed \$2,000, for various performances at our Holiday Hayride Events to provide musical entertainment on Fridays, December 8th & 15th, 2023 and Saturdays, December 9th & 16th, 2023 in Burnet Park.

The cost of these performances shall be charged to account number: 01.71400.540552.

If you have any questions or comments regarding this, please contact our office.

Sincerely,

Tony Williams
Commissioner

Syracuse Department
of Parks, Recreation
& Youth Programs
412 Spencer Street
Syracuse, N.Y. 13204

Office 315 473 4330
Fax 315 428 8513

www.syrgov.net

2

Ordinance No.

2023

ORDINANCE AUTHORIZING A WAIVER OF COMPETITIVE BIDDING TO AUTHORIZE AN AGREEMENT BETWEEN THE CITY AND ROUTE 80 QUARRY RIDGE STABLES TO PROVIDE HORSE-DRAWN WAGON RIDES AS PART OF THE DEPARTMENT OF PARKS, RECREATION AND YOUTH PROGRAMS ANNUAL HOLIDAY HAYRIDE EVENTS AT BURNET PARK

WHEREAS, the Department of Parks, Recreation and Youth Programs has requested approval of an agreement between the City and Route 80 Quarry Ride Stables relative to providing horse-drawn wagon rides for four (4) nights as part of the Department of Parks, Recreation and Youth Programs Annual Holiday Hayride events at Burnet Park, which are scheduled to be held December 8, 9, 15, 16, 2023; and

WHEREAS, the Director of Management and Budget has waived the competitive bidding process for this Agreement and has approved the retention of Route 80 Quarry Ridge Stables; NOW, THEREFORE,

BE IT ORDAINED, that this Common Council hereby authorizes the Mayor to enter into an agreement with Route 80 Quarry Ridge Stables relative to the provision of horse-drawn wagon rides for four (4) nights as part of the Department of Parks, Recreation and Youth Programs Hayride Events at Burnet Park at a cost not to exceed \$5,200.00; and

BE IT FURTHER ORDAINED, that the terms of the agreement shall be subject to the approval of the Corporation Counsel; and

BE IT FURTHER ORDAINED, that the cost for said agreement shall be charged shall be charged in part to Celebrations Account #504610.25.71400 and any remainder due shall be charged

to Account #01.71400.540552 or another appropriate account as designated by the Commissioner of Finance.

DRAFT



15

OFFICE OF MANAGEMENT & BUDGET

CITY OF SYRACUSE, MAYOR BEN WALSH

October 6, 2023

Timothy M. Rudd
Director

Julie Castellitto
Assistant Director

Ms. Patricia McBride
City Clerk
City Hall
Syracuse, New York

RE: Request for Legislation

Dear Ms. McBride:

On behalf of the Department of Parks, Recreation and Youth Programs, please prepare legislation for the next scheduled Common Council meeting to authorize a waiver of competitive bid to enter into an agreement with Route 80 Quarry Ridge Stables, in an amount not to exceed \$5,200. This agreement shall be for the Parks Department's Annual Holiday Hayrides event at Burnet Park. This event will take place on December 8, 9, 15, and 16, 2023 in Burnet Park.

Expenses to be paid will come from the Celebrations Account #504610 Fund #25 Department #71400 and any remaining balance charged to account number: 01.71400.540552.

We have been unable to find another local vendor/stable that is able to provide horses, wagons with adequate seating, as well as the required insurance policy to cover the City of Syracuse as additionally insured. This vendor has done an excellent job in the past with the Holiday Hayrides event at Burnet Park.

Sincerely,

Timothy M. Rudd
Director of Management and Budget

Office of Management
and Budget
233 E Washington St
Room 213
Syracuse, N.Y. 13202

Office 315 448-8252
Fax 315 448-8116

www.syr.gov.net



OFFICE OF MANAGEMENT & BUDGET

CITY OF SYRACUSE, MAYOR BEN WALSH

Timothy M. Rudd
Director

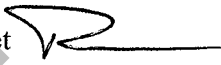
TO: Mayor Ben Walsh
FROM: Timothy M. Rudd, Director of Management & Budget 
DATE: October 6, 2023
SUBJECT: Waiver of Competitive Bid & Agreement – Route 80 Quarry Ridge Stables,

Julie Castellitto
Assistant Director

On behalf of the Department of Parks, Recreation & Youth Programs, I am requesting the City of Syracuse authorize a waiver of competitive bid to enter into an agreement with Route 80 Quarry Ridge Stables, in an amount not to exceed \$5,200. This agreement shall be for the Parks Department's Annual Holiday Hayrides event at Burnet Park. This event will take place on December 8, 9, 15, and 16, 2023 in Burnet Park.

Expenses to be paid will come from the Celebrations Account #504610 Fund #25 Department #71400 and any remaining balance charged to account number: 01.71400.540552.

We have been unable to find another local vendor/stable that is able to provide horses, wagons with adequate seating, as well as the required insurance policy to cover the City of Syracuse as additionally insured. This vendor has done an excellent job in the past with the Holiday Hayrides event at Burnet Park.

If you agree to enter into this agreement, please indicate by signing below and returning this memo to me so that I may forward a copy to the Common Council along with the legislation request for the next Common Council Meeting.

Thank you for your attention regarding this matter.



Mayor Ben Walsh
City of Syracuse, New York

10/6/23
Date

Office of Management
and Budget
233 E Washington St
Room 213
Syracuse, N.Y. 13202

Office 315 448-8252
Fax 315 448-8116

www.syr.gov.net



**DEPARTMENT OF PARKS,
RECREATION & YOUTH PROGRAMS**
CITY OF SYRACUSE, MAYOR BEN WALSH

October 5, 2023

Tony Williams
Commissioner

Chris Abbott
Deputy Commissioner

Mr. Timothy Rudd
Director of Budget
213 City Hall
Syracuse, NY 13202

RE: Request for Legislation – Holiday Hayrides 2023

Dear Mr. Rudd:

The Department of Parks Recreation and Youth Programs is requesting a waiver of competitive bid to enter into an agreement with Route 80 Quarry Ridge Stables, in an amount not to exceed \$5,200. This agreement shall be for the Parks Department's Annual Holiday Hayrides event at Burnet Park. This event will take place on December 8, 9, 15, and 16, 2023 in Burnet Park.

Expenses to be paid will come from the Celebrations Account #504610 Fund #25 Department #71400 and any remaining balance charged to account number: 01.71400.540552.

We have been unable to find another local vendor/stable that is able to provide horses, wagons with adequate seating, as well as the required insurance policy to cover the City of Syracuse as additionally insured. This vendor has done an excellent job in the past with the Holiday Hayrides event at Burnet Park.

If you have any questions or comments regarding this, please contact our office.

Sincerely,

Tony Williams
Commissioner

Syracuse Department
of Parks, Recreation
& Youth Programs
412 Spencer Street
Syracuse, N.Y. 13204

Office 315 473 4330
Fax 315 428 8513

www.syr.gov.net

Ordinance No.

2023

ORDINANCE AMENDING ORDINANCE NO. 775-2022 AUTHORIZING A TAX EXEMPTION AGREEMENT BETWEEN THE CITY OF SYRACUSE AND A HOUSING DEVELOPMENT CORPORATION TO BE FORMED BY ROCHESTER CORNERSTONE GROUP, LTD. TO BE KNOWN AS THE EASTWOOD HEIGHTS HOUSING DEVELOPMENT FUND CORPORATION (THE "CORPORATION") FOR THE PURPOSE OF CONSTRUCTING AND OPERATING AFFORDABLE HOUSING UNITS ON THE PROPERTY LOCATED AT 1025 SUNNYCREST ROAD, SYRACUSE, NEW YORK

BE IT ORDAINED, that Ordinance No. 775-2022 is hereby amended to read as follows:

WHEREAS, Rochester Cornerstone Group, Ltd, is creating a domestic not-for-profit corporation pursuant to Section 573 and Section 577 of Article XI of the New York Private Housing Finance Law (the "Act") and Section 402 of the New York State Not-for-Profit Corporation Law to be known as the Eastwood Heights Housing Development Fund Corporation (the "Corporation") and

WHEREAS, the Corporation is being formed for the purpose of constructing and operating affordable housing units on the property located at 1025 Sunnycrest Road, Syracuse, New York; and

WHEREAS, the Property is owned by the City of Syracuse and has been leased and operated by the Syracuse Housing Authority ("SHA") as a senior housing complex for several decades; and

WHEREAS, the Corporation proposes to lease the Property from SHA after SHA purchases the Property from the City; and

WHEREAS, the Corporation, to enable it to operate and extensively renovate the Property, has requested that the City of Syracuse, pursuant to the Act, grant a real property tax exemption for the Property, and enter into a tax exemption agreement (the "Agreement") with the Corporation; and

WHEREAS, the Corporation previously proposed the construction, operation and maintenance of forty-nine (49) affordable housing units at the Property and has now requested to increase the number of affordable housing units at the Property to fifty-three (53);

NOW THEREFORE,

BE IT ORDAINED, contingent upon there being no money due and owing to the City of Syracuse by SHA or the Corporation, that a real property tax exemption for the Property pursuant to the Act, is hereby authorized; and

BE IT FURTHER ORDAINED, that the Property shall be fully exempt upon the tax rolls of the City of Syracuse from all ad valorem real property taxes, but shall not be exempt from special assessments or other municipal and school district charges; and

BE IT FURTHER ORDAINED, that the Mayor, on behalf of the City of Syracuse, be and he is hereby authorized to enter into the Agreement with the Corporation, for the Property; and

BE IT FURTHER ORDAINED, that in consideration of the City granting the Corporation a real property tax exemption for the Property and entering into the Agreement, the Corporation shall make payments to be calculated each year based upon the City's standard shelter rent formula equal to (a) ten percent (10%) of annual gross revenues minus utilities or (b) \$29,150.00*, whichever is greater; and

BE IT FURTHER ORDAINED, that the Corporation will be required to provide an annual accounting of the gross rent and utilities to the City of Syracuse Finance Department; and

BE IT FURTHER ORDAINED, that the agreement shall take effect on the first taxable status date following transfer to the SHA and subsequent lease to the Corporation, that the Agreement shall be for a term of fifteen (15) years and shall contain such other terms and conditions as shall be determined by the Corporation Counsel to be in the best interest of the City of Syracuse .

_____ = new material

*Previously read \$26,950

DRAFT



DEPARTMENT OF ASSESSMENT

CITY OF SYRACUSE, MAYOR BEN WALSH

16

September 29, 2023

Matthew D. Oja
Commissioner

Patricia K. McBride
City Clerk
231 City Hall
Syracuse, New York 13202

Ann E. Gallagher
First Deputy
Commissioner
Director of Operations

Michael A. Lehmann
Deputy Commissioner

Re: Request for Legislation – Amendment of Ordinance No. 775-2022

Dear Ms. McBride:

The Department of Assessment requests that Ordinance Number 775 of 2022 be corrected to reflect a change in the properties to be included under the agreement.

The initial agreement authorized by Ordinance No. 775-2022 allowed the City of Syracuse to enter into a tax exemption agreement pursuant to Section 573 and Section 577 of Article 11 of the New York State Private Housing Finance Law and Section 402 of the New York State Not-For-Profit Corporation Law with a Housing Development Corporation to be formed by Rochester Cornerstone Group, Ltd, to be known as the Eastwood Heights Housing Development Fund Corporation (the "Corporation").

Under the terms of that prospective agreement, the Corporation was authorized to construct 49 units of affordable housing and benefit from a fifteen (15) -year exemption term under which payments to the City would be calculated each year based on the standard shelter rent formula equal to (a) ten percent (10%) of annual gross revenues minus utilities or (b) \$26,950, whichever is greater (this exemption is exclusive of special assessment or charges, which would still be due).

Under the revised agreement now contemplated, the unit count would be increased from the 49 apartments previously authorized. The Corporation would be authorized to construct 53 units of affordable housing. Payments to the City would still be calculated each year based on the standard shelter rent formula equal to (a) ten percent (10%) of annual gross revenues minus utilities or (b) \$29,150, whichever is greater (this exemption is exclusive of special assessment or charges, which would still be due).

All other portions of the item shall remain the same.

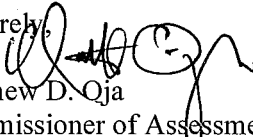
Sincerely,

Matthew D. Oja
Commissioner of Assessment

**Department of
Assessment**
233 E. Washington St
City Hall, Room 130
Syracuse, N.Y. 13202

Office 315 448 8270
assessment@syr.gov

GROWTH. DIVERSITY. OPPORTUNITY FOR ALL.

6



OFFICE OF MANAGEMENT & BUDGET

CITY OF SYRACUSE, MAYOR BEN WALSH

Timothy M. Rudd
Director

Julie Castellitto
Assistant Director

TO: Mayor Ben Walsh
FROM: Timothy M. Rudd, Director of Management and Budget 
DATE: September 29, 2023
SUBJECT: Amend Ordinance #775-2022 – Eastwood Heights Housing Development Fund Corporation formed by Rochester Cornerstone Group, Ltd

On behalf of the Department of Assessment, I am requesting the City amend Ordinance #775-2022 be corrected to reflect a change in the properties to be included under the agreement.

The initial agreement authorized by Ordinance No. 775-2022 allowed the City of Syracuse to enter into a tax exemption agreement pursuant to Section 573 and Section 577 of Article 11 of the New York State Private Housing Finance Law and Section 402 of the New York State Not For-Profit Corporation Law with a Housing Development Corporation to be formed by Rochester Cornerstone Group, Ltd, to be known as the Eastwood Heights Housing Development Fund Corporation (the "Corporation").

Under the terms of that prospective agreement, the Corporation was authorized to construct 49 units of affordable housing and benefit from a fifteen (15) -year exemption term under which payments to the City would be calculated each year based on the standard shelter rent formula equal to (a) ten percent (10%) of annual gross revenues minus utilities or (b) \$26,950, whichever is greater (this exemption is exclusive of special assessment or charges, which would still be due).

Under the revised agreement now contemplated, the unit count would be increased from the 49 apartments previously authorized. The Corporation would be authorized to construct 53 units of affordable housing. Payments to the City would still be calculated each year based on the standard shelter rent formula equal to (a) ten percent (10%) of annual gross revenues minus utilities or (b) \$29,150, whichever is greater (this exemption is exclusive of special assessment or charges, which would still be due).

All other portions of the item shall remain the same.

Please indicate your concurrence by signing below and returning this memo to me so that I may then forward your approval to the Common Council along with the request for authorizing this legislation.

Thank you for your attention regarding this matter.

Office of Management and Budget
233 E Washington St
Room 213
Syracuse, N.Y. 13202

Office 315 448-8252
Fax 315 448-8116

www.syr.gov

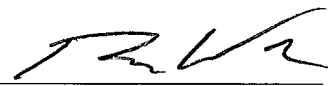

Mayor Ben Walsh
City of Syracuse, New York

10/4/23
Date

Ordinance No.

2023

ORDINANCE AUTHORIZING A TAX EXEMPTION AGREEMENT BETWEEN THE CITY OF SYRACUSE AND A HOUSING DEVELOPMENT CORPORATION TO BE FORMED BY COR VAN RENSSELAER STREET COMPANY IV, TO BE KNOWN AS THE AERIE HOUSING DEVELOPMENT FUND COMPANY (THE "COMPANY") FOR THE PURPOSE OF CONSTRUCTING AND OPERATING AFFORDABLE HOUSING UNITS ON THE PROPERTY LOCATED AT 710 VAN RENSSELAER STREET, SYRACUSE, NEW YORK (SBL 117.-01-01.4)

WHEREAS, COR Van Rensselaer Street Company IV, is creating a domestic not-for-profit corporation pursuant to Section 573 and Section 577 of Article XI of the New York Private Housing Finance Law (the "Act") and Section 402 of the New York State Not-for-Profit Corporation Law to be known as the Aerie Housing Development Fund Company (the "Company") and

WHEREAS, the Company is being formed for the purpose of constructing and operating affordable housing units on the property located at 710 Van Rensselaer Street, Syracuse, New York (SBL 117.-01-01.4) (the "Property"); and

WHEREAS, the Property is vacant lot adjacent to the Inner Harbor; and

WHEREAS, the Company proposes to construct and operate sixty-two (62) units of affordable housing on the Property, to create needed housing and preserve affordability in a centrally located neighborhood; and

WHEREAS, the Company, to enable it to operate and extensively renovate the Property, has requested that the City of Syracuse, pursuant to the Act, grant a real property tax exemption for the Property, and enter into a tax exemption agreement (the "Agreement") with the Company;

NOW THEREFORE,

BE IT ORDAINED, contingent upon there being no money due and owing to the City of Syracuse by COR Van Rensselaer Street Company IV, that a real property tax exemption for the Property pursuant to the Act, is hereby authorized; and

BE IT FURTHER ORDAINED, that the Property shall be fully exempt upon the tax rolls of the City of Syracuse from all ad valorem real property taxes, but shall not be exempt from special assessments or other municipal and school district charges; and

BE IT FURTHER ORDAINED, that the Mayor, on behalf of the City of Syracuse, be and he is hereby authorized to enter into the Agreement with the Company for the Property; and

BE IT FURTHER ORDAINED, that in consideration of the City granting the Company a real property tax exemption for the Property and entering into the Agreement, the Company shall make payments to be calculated each year based upon the City's standard shelter rent formula equal to (a) ten percent (10%) of annual gross revenues minus utilities or (b) \$34,100.00, whichever is greater; and

BE IT FURTHER ORDAINED, that the Company will be required to provide an annual accounting of the gross rent and utilities to the City of Syracuse Finance Department; and

BE IT FURTHER ORDAINED, that the agreement shall be for a term of fifteen (15) years with the option of a fifteen (15) year renewal period to be exercised by the tenant subject to the approval of the Mayor and Common Council; and

BE IT FURTHER ORDAINED, that the agreement shall contain such other terms and conditions as shall be determined by the Corporation Counsel to be in the best interest of the City of Syracuse.



DEPARTMENT OF ASSESSMENT

CITY OF SYRACUSE, MAYOR BEN WALSH

17

September 29, 2023

Matthew D. Oja
Commissioner

Patricia K. McBride
City Clerk
231 City Hall
Syracuse, New York 13202

Ann E. Gallagher
First Deputy
Commissioner
Director of Operations

Michael A. Lehmann
Deputy Commissioner

Re: Request for Legislation to Authorize a Tax Exemption Agreement Pursuant to the New York State Private Housing Finance Law with a Housing Development Fund Corporation to be formed by COR Van Rensselaer Street Company IV that shall be known as Aerie Housing Development Fund Company, Inc.

Dear Ms. McBride:

Please prepare legislation for the next Common Council meeting authorizing the City of Syracuse to enter into a tax exemption agreement pursuant to Section 573 and Section 577 of Article 11 of the New York State Private Housing Finance Law and Section 402 of the New York State Not-For-Profit Corporation Law with a Housing Development Corporation to be formed by property owner COR Van Rensselaer Street Company IV, to be known as the Aerie Housing Development Fund Company, Inc. (the "Company"). The tax exemption agreement shall involve the property at 710 Van Rensselaer Street (SBL 117.-01-01.4), currently a vacant lot adjacent to the Inner Harbor.

This exemption will enable the Company to construct 62 units of affordable housing. This exemption will enable the Company to create needed housing and preserve affordability in a centrally-located city neighborhood.

This agreement with the Company would be for a term of fifteen (15) years and would not exempt it from special assessments or charges on the properties. The Company's payments to the City would be calculated each year based on the standard shelter rent formula equal to (a) ten percent (10%) of annual gross revenues minus utilities or (b) \$34,100, whichever is greater. This agreement also includes a fifteen (15) -year renewal option to be exercised by tenant via Common Council and Mayoral authorization.

Department of Assessment
233 E. Washington St
City Hall, Room 130
Syracuse, N.Y. 13202

Office 315 448 8270
assessment@syr.gov

Sincerely,

Matthew D. Oja
Commissioner of Assessment

GROWTH. DIVERSITY. OPPORTUNITY FOR ALL.

3A



OFFICE OF MANAGEMENT & BUDGET

CITY OF SYRACUSE, MAYOR BEN WALSH

Timothy M. Rudd
Director

Julie Castellitto
Assistant Director

TO: Mayor Ben Walsh
FROM: Timothy M. Rudd, Director of Management and Budget 
DATE: September 29, 2023
SUBJECT: Tax Exemption Agreement with Aerie Housing Development Fund Company, Inc. formed by COR Van Rensselaer Street Company IV

On behalf of the Department of Assessment, I am requesting the City of Syracuse to enter into a tax exemption agreement pursuant to Section 573 and Section 577 of Article 11 of the New York State Private Housing Finance Law and Section 402 of the New York State Not-For-Profit Corporation Law with a Housing Development Corporation to be formed by property owner COR Van Rensselaer Street Company IV, to be known as the Aerie Housing Development Fund Company, Inc. (the "Company"). The tax exemption agreement shall involve the property at 710 Van Rensselaer Street (SBL 117.-01-01.4), currently a vacant lot adjacent to the Inner Harbor.

This exemption will enable the Company to construct 62 units of affordable housing. This exemption will enable the Company to create needed housing and preserve affordability in a centrally-located city neighborhood.

This agreement with the Company would be for a term of fifteen (15) years and would not exempt it from special assessments or charges on the properties. The Company's payments to the City would be calculated each year based on the standard shelter rent formula equal to (a) ten percent (10%) of annual gross revenues minus utilities or (b) \$34,100, whichever is greater. This agreement also includes a fifteen (15) -year renewal option to be exercised by tenant via Common Council and Mayoral authorization.

Please indicate your concurrence by signing below and returning this memo to me so that I may then forward your approval to the Common Council along with the request for authorizing this legislation.

Thank you for your attention regarding this matter.

Office of Management
and Budget
233 E Washington St
Room 213
Syracuse, N.Y. 13202

Office 315 448-8252
Fax 315 448-8116

www.syr.gov



Mayor Ben Walsh
City of Syracuse, New York

Date

Ordinance No.

2023

**ORDINANCE AUTHORIZING CORRECTION OF
TAX ROLLS**

BE IT ORDAINED, that the Commissioner of Finance be and he is hereby directed to correct the tax rolls as shown on the attached Appendix "A".

DRAFT

IS

SHOULD BE

Charles Brady Corp. of CNY
117 Game Road
1431000105
061.-02-32.0
LAND - \$66,200
FULL - \$108,800
CITY TAXABLE - \$590,000
COUNTY TAXABLE - \$590,000
SCHOOL TAXABLE - \$590,000
EXEMPTION - [None] - \$0
ALL OTHER CHARGES AS BILLED

Charles Brady Corp. of CNY
117 Game Road
1431000105
061.-02-32.0
LAND - \$66,200
FULL - \$108,800
CITY TAXABLE - \$0
COUNTY TAXABLE - \$0
SCHOOL TAXABLE - \$0
EXEMPTION - 25130 - \$590,000
ALL OTHER CHARGES AS BILLED

DRAFT



DEPARTMENT OF ASSESSMENT

CITY OF SYRACUSE, MAYOR BEN WALSH

18

September 29, 2023

Matthew D. Oja
Commissioner

Ann E. Gallagher
First Deputy
Commissioner
Director of Operations

Michael A. Lehmann
Deputy Commissioner

Patricia K. McBride
City Clerk
231 City Hall
Syracuse, New York 13202

Re: Request for Legislation – Correction of Records

Dear Ms. McBride:

Please prepare legislation for the next Common Council meeting authorizing the Commissioner of Finance to correct his records according to the changes to the 2023/2024 assessment roll outlined in Appendix "A" (attached).

This property has been reviewed and we find that the corrections to be made are in order.

Sincerely,

Matthew D. Oja
Commissioner of Assessment

**Department of
Assessment**
233 E. Washington St
City Hall, Room 130
Syracuse, N.Y. 13202

Office 315 448 8270

assessment@syr.gov

GROWTH. DIVERSITY. OPPORTUNITY FOR ALL.

5



OFFICE OF PERSONNEL & LABOR RELATIONS

CITY OF SYRACUSE, MAYOR BEN WALSH

19

October 3, 2023

Richard Alsever
Director

Patricia McBride
City Clerk
231 City Hall
Syracuse, NY 13202

Margaret Chajka
Assistant Director

RE: Request Legislation Awarding Aetna Contract, RFP #23-7100-001 (County, City, SCSD)

Clerk McBride,

Please prepare legislation for the next meeting of the Common Council awarding Aetna the contract for City retiree health and pharmaceutical benefit management effective January 1, 2024. The contract is being awarded for three years with the possibility of two, one-year extensions. The City will pay a blended monthly rate for all retirees (New York State and Non) of \$158.16. All costs shall be charged to Account No. 590601.01.90600. The total amount of the three-year contract shall not exceed \$11,000,000, estimated \$3,666,666 annually.

Best,

Richard Alsever
Director of Human Resources

CC: Frank Caliva, Chief Administrative Officer
CC: Timothy Rudd, Budget Director

Office of Personnel & Labor Relations
233 E. Washington St
City Hall, Room 312
Syracuse, N.Y. 13202

Office 315 448-8780
Fax 315 448-8761

www.syr.gov.net



OFFICE OF MANAGEMENT & BUDGET

CITY OF SYRACUSE, MAYOR BEN WALSH

Timothy M. Rudd
Director

Julie Castellitto
Assistant Director

TO: Mayor, Ben Walsh
FROM: Timothy M. Rudd, Director of Management and Budget 
DATE: October 6, 2023
SUBJECT: Agreement RFP#23-7100-001 (County, City, SCSD) – Aetna

On behalf of the Office of Personnel & Labor Relations, I am requesting the City award Aetna the contract for City retiree health and pharmaceutical benefit management effective January 1, 2024. The contract is being awarded for three years with the possibility of two, one-year extensions. The City will pay a blended monthly rate for all retirees (New York State and Non) of \$158.16. All costs shall be charged to Account No. 590601.01.90600. The total amount of the three-year contract shall not exceed \$11,000,000, estimated \$3,666,666 annually.

Please indicate your concurrence by signing below and returning this memo to me so that I may forward a copy to the Common Council along with the legislation request for the next Common Council Meeting.

Thank you for your attention regarding this matter.



Mayor Ben Walsh
City of Syracuse, New York

10/6/23
Date

Office of Management
and Budget
233 E Washington St
Room 213
Syracuse, N.Y. 13202

Office 315 448-8252
Fax 315 448-8116

www.syr.gov



20

DEPARTMENT OF PUBLIC WORKS

CITY OF SYRACUSE, MAYOR BEN WALSH

September 29, 2023

Jeremy Robinson
Commissioner

Ann Fordock
Deputy Commissioner

Martin E. Davis, L.S.
Deputy Commissioner

Ms. Patricia K. McBride
Office of the City Clerk
233 E. Washington Street, Room 231
Syracuse, N.Y. 13202

Request for Legislation – Accept a Permanent Easement from TLSP CODA, LLC, the Owner of the CODA Apartment Project (399 South Crouse Avenue) along the 300 Block of South Crouse to Facilitate the Public Use of a Sidewalk.

Dear Ms. McBride:

I request the following legislation for the next meeting of the Common Council be prepared:

An Ordinance authorizing the City of Syracuse to – Accept a Permanent Easement from TLSP CODA, LLC, the Owner of the CODA Apartment Project (399 South Crouse Avenue) along the 300 Block of South Crouse Avenue to Facilitate the Public Use of a Sidewalk. The ownership and maintenance of the sidewalk shall fall under the responsibilities for sidewalk as defined in the City Charter.

The easement is required as the existing R.O.W. is too narrow to construct the sidewalk in accordance with applicable standards.

This department has reviewed, coordinated with other City departments and is of the opinion that the easement is a benefit to the public use of the streets. It is therefore, recommended for consideration by the Common Council to accept a permanent easement from TLSP CODA, LLC for the pedestrian infrastructure improvements at no cost to the City in and along the aforementioned permanent easement that will be granted to the City of Syracuse along the 300 Block of South Crouse Avenue and as shown on the drawing as forwarded to the Department of Engineering prepared by CHA entitled "Parking Plan" dated September 13th, 2023. A copy of the survey and the legal description of the proposed easement are attached.

Dept. of Public Works
1200 Canal St. Extension
Syracuse, N.Y. 13210

Office 315 448-2489
Fax 315 448-8531

www.syr.gov

1. TLSP CODA, LLC shall record said right of way and easements with map, legal description and monuments with the County of Onondaga, State of New York, subject to approval by the City Engineer and the Commissioner of Public Works.
2. That TLSP CODA, LLC, its successors or assigns, shall within thirty (30) days from the adoption of this Ordinance execute and file in the Office of the City Clerk written acceptance of this ordinance.

3. The foregoing conditions may be modified or expanded from time to time as agreed upon by the Corporation Counsel, City Engineer and TLSP CODA, LLC.

Additional terms and conditions, as recommended by the City Engineer and the Corporation Counsel, shall be set forth in the Ordinance.

Very truly yours,

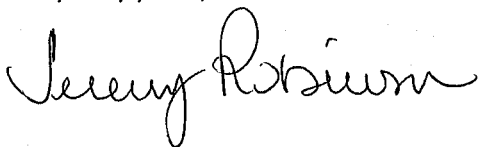



















Jeremy Robinson
DPW Commissioner

CC:

Mary E. Robison, City Engineer

DRAFT

LEGEND:

-  Indicates light stand
-  Indicates utility pole, outdoor & overhead lines
-  Indicates man hole and/or manhole found
-  Indicates sidewalk
-  Indicates sign
-  Indicates storm sewer
-  Indicates gas main, gas valve & gas line marker
-  Indicates water main, water valve & hydrant
-  Indicates storm sewer catch basin & manhole
-  Indicates sanitary sewer, sewer vent & manhole
-  Indicates underground telephone box, manhole & box
-  Indicates underground electric line & manhole
-  Indicates underground fire alarm cable & box
-  Indicates boundary line
-  Indicates adjacent parcel line
-  Indicates old/original parcel line
-  Indicates easement line
-  Indicates cartilage road

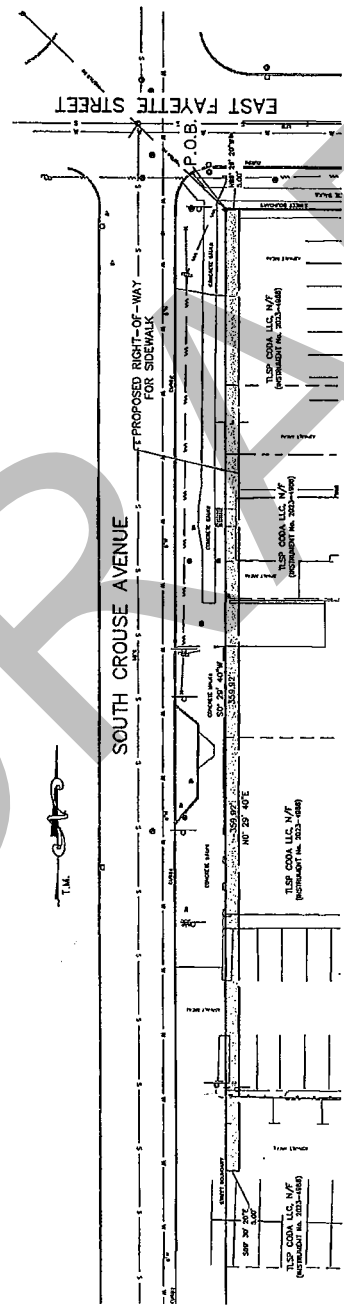

CITY OF SYRACUSE
DEPARTMENT OF PUBLIC WORKS

ACQUIRED FROM
 LAND INVESTING P.C.
 PART OF BLOCK No. 221
 CITY OF SYRACUSE
 ONONDAGA COUNTY, NEW YORK

LAND INVESTING P.C.
 1400 SYRACUSE, NY 13211
 PHONE: (315) 437-4000
 FAX: (315) 437-4001
 DATE: 10/20/2004

DATE: SEPTEMBER 8, 2023
 SHEET 1" = 20'
 FILE NO. 2238.104

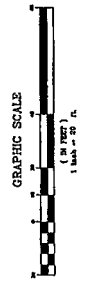

R.O.W. No. 578
2286.104
AD
9-6-2023

CITY OF SYRACUSE
RIGHT-OF-WAY FOR
SIDEWALK
TO BE ACQUIRED FROM
TLSP CODA LLC

All that tract or parcel of land situate in the City of Syracuse, County of Onondaga and State of New York, being part of Block No. 221 in said City, being part of lands conveyed to TLSP CODA LLC by deed recorded as Instrument No. 2023-4988 in the Onondaga County Clerk's Office, bounded and described as follows:

Beginning at a point in the southerly boundary of East Fayette Street at its intersection with the easterly boundary of South Crouse Avenue; running thence S 0°29'40" W along said easterly boundary of South Crouse Avenue, a distance of 359.92 feet to a point therein; thence S 89°30'20" E through said lands conveyed to TLSP CODA LLC, a distance of 5.00 feet to a point; thence N 0°29'40" E continuing through said lands conveyed to TLSP CODA LLC, a distance of 359.92 feet to a point in said southerly boundary of East Fayette Street; thence N 89°29'20" W along said southerly boundary of East Fayette Street, a distance of 5.00 feet to the point of beginning.

Subject to any other easements and restrictions of record.



21

DEPARTMENT OF ASSESSMENT

CITY OF SYRACUSE, MAYOR BEN WALSH

October 5, 2023

Matthew D. Oja
Commissioner

Patricia K. McBride
City Clerk
230 City Hall
Syracuse, New York 13202

Ann E. Gallagher
First Deputy
Commissioner
Director of Operations

Re: Request for Legislation – Amendment of Ordinance No. 180-2019

Michael A. Lehmann
Deputy Commissioner

Dear Ms. McBride:

The Department of Assessment requests that Ordinance Number 180 of 2019 be amended to allow the following modifications to the lease agreement for the City-owned Madison-Irving parking garage, located at 445 Irving Avenue.

The term of the Parking Agreement, between the City of Syracuse (the “City”) and Rothschild Development Corporation (the “Company”), commenced on July 1, 2019, to expire on June 30, 2029. The Company and the City hereby acknowledge and mutually agree that with the execution of this Amendment, the term shall be extended to June 30, 2038.

Under the Parking Agreement prior to this Amendment, the Permit Charge for up to 190 group rate parking permits is as follows:

Period	Years	Monthly Rate Without Tax	Monthly Rate With Tax (assuming 8%)
7/1/2019 – 6/30/2024	5	\$65.00	\$70.20
7/1/2024 – 6/30/2029	5	\$70.00	\$75.60

The Company and the City agree that pursuant to this Amendment, the Permit Charge for up to 190 group rate parking permits shall be as follows:

Period	Years	Monthly Rate Without Tax	Monthly Rate With Tax (assuming 8%)
Effective Date - 6/30/2028	-	\$70.00	\$75.60
7/1/2028 – 6/30/2033	5	\$80.00	\$86.40
7/1/2033 – 6/30/2038	5	\$90.00	\$97.20

The City hereby grants to Company during the term of this Lease, or any extension thereto, a right of first refusal to purchase the Garage. When the City receives a bona fide third-party offer to purchase or ground-lease the Garage, the Company shall have fourteen (14) calendar days to exercise Company’s right of first refusal upon the same or substantially the same terms and conditions as in such bona fide written offer in possession of the City.

All other portions of the item shall remain the same.

Sincerely,

Matthew D. Oja
Commissioner of Assessment

Department of Assessment
233 E. Washington St.
City Hall, Room 130
Syracuse, N.Y. 13202

Office 315 448 8270
assessment@syr.gov

35



OFFICE OF MANAGEMENT & BUDGET

CITY OF SYRACUSE, MAYOR BEN WALSH

Timothy M. Rudd
Director

Julie Castellitto
Assistant Director

TO: Mayor Ben Walsh
FROM: Julie Castellitto, Assistant Director of Management and Budget *JC*
DATE: October 5, 2023
SUBJECT: Amend Ordinance #180-2019 – Rothschild Development Corporation

On behalf of the Department of Assessment, I am requesting Ordinance #180 -2019 be amended to allow the following modifications to the lease agreement for the City-owned Madison-Irving parking garage, located at 455 Irving Avenue.

The term of the Parking Agreement, between the City of Syracuse (the “City”) and Rothschild Development Corporation (the “Company”), commenced on July 1, 2019, to expire on June 30, 2029. The Company and the City hereby acknowledge and mutually agree that with the execution of this Amendment, the term shall be extended to June 30, 2028.

Under the Parking Agreement prior to this Amendment, the Permit Charge for up to 190 group rate parking permits is as follows:

Period	Years	Monthly Rate Without Tax	Monthly Rate With Tax (assuming 8%)
7/1/2019 – 6/30/2024	5	\$65.00	\$70.20
7/1/2024 -6/30/2029	5	\$70.00	\$75.60

The Company and the City agree that pursuant to this Amendment, the Permit Charge for up to 190 group rate parking permits shall be as follows:

Period	Years	Monthly Rate Without Tax	Monthly Rate With Tax (assuming 8%)
Effective Date – 6/30/2028	-	\$70.00	\$75.60
7/1/2028 – 6/30/2033	5	\$80.00	\$86.40
7/1/2033 – 6/30/2038	3	\$90.00	\$97.20

Office of Management and Budget
233 E Washington St
Room 213
Syracuse, N.Y. 13202

Office 315 448-8252
Fax 315 448-8116

www.syr.gov

The City hereby grants to Company during the term of this Lease, or any extension thereto, a right of first refusal to purchase the Garage. When the City shares Pertinent Information with a third-party, the City shall provide the same to the Company. When the City receives a bona fide third-party offer to purchase or lease the Garage, the Company shall have fourteen (14) calendar days to exercise Company’s right of first refusal upon the same or substantially the same terms and conditions as in such bona fide written offer in possession of the City.

All other portions of the item shall remain the same.

Please indicate your concurrence by signing below and returning this memo to me so that I may then forward your approval to the Common Council along with the request for authorizing this legislation.

Thank you for your attention regarding this matter.



Mayor Ben Walsh
City of Syracuse, New York

OCT 05 2023

Date

DRAFT

Revised Appendix A

445 Irving Avenue (Madison-Irving Garage) Rent Schedule

Original

Period	Monthly Rate Without Tax	Monthly Rate With Tax (Assuming 8%)
7/1/2019 – 6/30/2020	\$65.00	\$70.20
7/1/2020 – 6/30/2021	\$65.00	\$70.20
7/1/2021 – 6/30/2022	\$65.00	\$70.20
7/1/2022 – 6/30/2023	\$65.00	\$70.20
7/1/2023 – 6/30/2024	\$65.00	\$70.20
7/1/2024 – 6/30/2025	\$70.00	\$75.60
7/1/2025 – 6/30/2026	\$70.00	\$75.60
7/1/2026 – 6/30/2027	\$70.00	\$75.60
7/1/2027 – 6/30/2028	\$70.00	\$75.60
7/1/2028 – 6/30/2029	\$70.00	\$75.60

Revised

Period	Monthly Rate Without Tax	Monthly Rate With Tax (Assuming 8%)
7/1/2024 – 6/30-2025	\$70.00	\$75.60
7/1/2025 – 6/30/2026	\$70.00	\$75.60
7/1/2026 – 6/30/2027	\$70.00	\$75.60
7/1/2027 – 6/30/2028	\$70.00	\$75.60
7/1/2028 – 6/30/2029	\$80.00	\$86.40
7/1/2029 – 6/30/2030	\$80.00	\$86.40
7/1/2030 – 6/30/2031	\$80.00	\$86.40
7/1/2031 – 6/30/2032	\$80.00	\$86.40
7/1/2032 – 6/30/2033	\$80.00	\$86.40
7/1/2033 – 6/30/2034	\$90.00	\$97.20
7/1/2034 – 6/30/2035	\$90.00	\$97.20
7/1/2035 – 6/30/2036	\$90.00	\$97.20
7/1/2036 – 6/30/2037	\$90.00	\$97.20
7/1/2037 – 6/30/2038	\$90.00	\$97.20

Ordinance No.

2023

**ORDINANCE AUTHORIZING THE
DEPARTMENT OF PUBLIC WORKS
TO PROCEED WITH THE 2023/2024
CITY OWNED BUILDINGS IMPROVEMENT
AND RECONSTRUCTION PROJECTS**

BE IT ORDAINED, that this Common Council hereby authorizes the Department of Public Works to proceed with the 2023/2024 City Owned Buildings Improvement and Reconstruction Projects which will include the completion of necessary improvements and reconstruction projects at City Hall, the Department of Public Works facilities, and other City owned buildings, at a total cost not to exceed \$600,000.00; and the Director of Management & Budget is hereby authorized to purchase necessary equipment and enter into a contract or contracts for the projects in the manner provided by law; charging the cost thereof to the proceeds from the sale of bonds authorized contemporaneously herewith by ordinance of this Common Council.

DRAFT



22-23

DEPARTMENT OF PUBLIC WORKS

CITY OF SYRACUSE, MAYOR BEN WALSH

September 22, 2023

Jeremy Robinson
Commissioner

Ann Fordock
Deputy Commissioner

Martin E. Davis, L.S.
Deputy Commissioner

Ms. Patricia K. McBride
Office of the City Clerk
231 City Hall
Syracuse, New York 13202

Request for Legislation: Authorization and Bonding for 2023/2024 City Owned Building Improvements and Reconstruction

Dear Ms. McBride:

Please prepare the following legislation for the next meeting of the Syracuse Common Council:

- Ordinance authorizing the Department of Public Works to proceed with the 2023/2024 City Owned Building Improvements and Reconstruction at a cost not to exceed \$600,000.00.
- Ordinance to authorize the sale and issuance of bonds to defray the cost and expense of 2023/2024 City Owned Building Improvements and Reconstruction at a cost not to exceed \$600,000.00.

This funding will be used to complete necessary improvements and reconstruction to City Hall, DPW and other City owned buildings. The Department of Public Works facility needs numerous improvements, and this funding will also be used for other necessary improvements and reconstruction needed at City Hall and other City owned buildings.

Please let me know if you have any questions relative to this request.

Sincerely,

Jeremy Robinson
Commissioner of Public works

Dept. of Public Works
1200 Canal St. Extension
Syracuse, N.Y. 13210

Office 315 448-2489
Fax 315 448-8531

www.syr.gov.net

13



City of Syracuse

AUTHORIZATION TO PROCEED WITH CIP PROJECT

Date: 09/22/23 Department: Public Works
 Project Name: 2023 2024 City Owned Building Improvements
 Project Cost: \$600,000
 Contact Name: Jeremy Robinson
 Project Description: Funds to use on improvements and reconstruction needed to City Hall, DPW and other City Owned Buildings. *300k from Engineering CIP and 300k leftover from Interstate Lighting DPW CIP, Mary Robison agreed to move from Engineering CIP to DPW CIP*

Projected Time Line & Funding Source(s)

Estimated Start Date: 10/1/2023 Estimated Completion Date: as required

Funding Source:	Dollar Amount:
Local Share: Cash Capital	\$0
Local Share: Bonds (complete schedule below)	\$600,000
State Aid/Grant (identify)	\$0
Federal Aid/Grant (identify) (TIP)	\$0
Other (identify) Syracuse University	\$0
Other (identify) Onondaga County	\$0
Total Project Funding (must equal cost):\$	\$600,000

Estimated Project Borrowing Timeline

Year	Fiscal Year	Estimated Amount to Borrow
1	2024	\$600,000
2	0	\$0
3	0	
4		
5		
Total Estimated Amount to Borrow (if different than "Local Share: Bonds" above, explain)		\$ 600,000

Approval to proceed with request for legislation is hereby granted.

Project in CIP Plan: Yes No Reason("No"): CIP 2022/23

Director of Administration: *[Signature]* Date: _____
 Director of Management & Budget: *[Signature]* Date: 9-22-23 *[Signature]*
 Commissioner of Finance: *[Signature]* Date: 10/3/23

Ordinance No.

2023

ORDINANCE AMENDING ORDINANCE NO. 652-2021 AS LAST AMENDED BY ORDINANCE NO. 701-2022 AUTHORIZING AN AGREEMENT BETWEEN THE CITY OF SYRACUSE AND SUNY UPSTATE MEDICAL UNIVERSITY (“SUNY UPSTATE”) RELATING TO THE PROVISION OF WHITE ROAD SALT FROM THE CITY FACILITY AT THE DEPARTMENT OF PUBLIC WORKS

BE IT ORDAINED., that Ordinance No. 652-2021 as last amended by Ordinance No. 701-2022 is hereby further amended to read as follows:

WHEREAS, SUNY Upstate Medical University (“SUNY Upstate”) has requested that the City of Syracuse provide SUNY Upstate with white road salt from the City’s Department of Public Works Facility at a cost per ton plus \$5.00 per ton administrative fee, with the base cost per ton being the City’s actual cost per ton for each year of the agreement; and

WHEREAS, the Commissioner of Public Works has recommended that said agreement be for a one-year term commencing with the 2021/2022 winter season with the option of four additional one-year renewal periods subject to the approval of the Mayor and Common Council:

NOW, THEREFORE,

BE IT ORDAINED, that the Mayor, on behalf of the City of Syracuse, is hereby authorized to enter into a municipal cooperation agreement with SUNY Upstate in relation to the provision of white road salt for use by SUNY Upstate from the City’s Department of Public Works facility at the City’s actual cost per ton, the 2021/2022 rate per ton was \$39.57, plus a \$5.00 per ton administrative fee, for a total cost of \$44.57 per ton; and

BE IT FURTHER ORDAINED, that pursuant to Ordinance No. 701-2022 the agreement with SUNY Upstate was extended for the first one year renewal period at the City’s actual cost

per ton, the 2022/2023 rate per ton was \$44.28 per ton, plus a \$5.00 per ton administrative fee, for a total cost of \$49.28 per ton for the first one-year renewal period; and

BE IT FURTHER ORDAINED, that the agreement with SUNY Upstate authorized herein is hereby extended for the second one-year renewal period at the City's actual cost per ton, the 2023/2024 rate per ton is \$49.20 per ton, plus a \$5.00 per ton administrative fee, for a total cost of \$54.20 per ton for the second one-year renewal period; and

BE IT FURTHER ORDAINED, that the City's Commissioner of Public Works shall administer the system so as to provide for coordination and scheduling of use of the City Facility which will accommodate the provision of white road salt for City and SUNY Upstate; and

BE IT FURTHER ORDAINED, that SUNY Upstate shall at all times provide its own vehicles for receipt and transportation of the white road salt; and

BE IT FURTHER ORDAINED that the City shall not be responsible for the white road salt supply or lack thereof for reasons beyond the City's control, including but not limited to strike, white. road salt shortage, or late deliveries from suppliers of white road salt; and

BE IT FURTHER ORDAINED, that the initial term of the agreement shall be for one (1) year commencing on or about November 1, 2021 through April 30, 2022, with the option of four (4) additional one-year renewal periods subject to the approval of the Mayor and Common Council, and further that either the City or SUNY Upstate may, notwithstanding the term of the contract, terminate this contract at any time upon thirty (30) days written notice to the other party, provided that all costs and expenses due or accruing under such agreement shall be promptly paid on or prior to the date of termination; and

BE IT FURTHER ORDAINED, that this agreement was previously extended for the first one year renewal period and is hereby extended for the second one (1) year renewal period commencing on or about November 1 2023 through April 30, 2024; and

BE IT FURTHER ORDAINED, that this amended agreement shall be subject to the necessary approvals of SUNY Upstate and copies of the approval shall be submitted to the Corporation Counsel; and

BE IT FURTHER ORDAINED, that this amended agreement shall contain such additional terms and conditions as the Corporation Counsel shall determine to be in the best interest of the City.

_____ = new material

DRAFT



24

DEPARTMENT OF PUBLIC WORKS

CITY OF SYRACUSE, MAYOR BEN WALSH

September 21, 2023

Jeremy Robinson
Commissioner

Ann Fordock
Deputy Commissioner

Martin E. Davis, L.S.
Deputy Commissioner

Ms. Patricia McBride
City Clerk
230 City Hall
Syracuse, NY 13202

Re: Request to Renew the Agreement with SUNY Upstate Medical University and the City of Syracuse Department of DPW for the sale of White Road Salt

Dear Ms. McBride:

Please prepare legislation for the upcoming meeting of the common council to renew the agreement between SUNY Upstate Medical University and the City of Syracuse Department of DPW for the sale of white road salt, exercising the second one (1) year extension of the four (4) available extensions. The term of this agreement shall commence with the 2023/2024 winter season.

Amend ordinance # 701-2022 to renew for the 2023/2024 winter season commencing on or about November 1, 2023 through April 30, 2024.

The rate charged to SUNY Upstate Medical University for the 2023/2024 season will include the cost to the City for purchasing white road salt of \$49.20 per ton, plus a \$5.00 administrative fee per ton, for a total of \$54.20 per ton. The City received a price of \$44.28 for the 2022/2023 season and that has gone up for the 2023/2024 season to \$49.20 per ton. Revenue from the sale of white road salt will be deposited into Revenue Account #417120 01.

Should you have any questions, please do not hesitate to contact me.

Very truly yours,

Jeremy Robinson
Commissioner of Public Works

Dept. of Public Works
1200 Canal St. Extension
Syracuse, N.Y. 13202

Office 315 448-2489
Fax 315 448-8531

www.syr.gov.net

7



OFFICE OF MANAGEMENT & BUDGET

CITY OF SYRACUSE, MAYOR BEN WALSH

Timothy M. Rudd
Director

TO: Mayor Ben Walsh
FROM: Timothy M. Rudd, Director of Management and Budget 
DATE: September 28, 2023
SUBJECT: Amend Agreement – SUNY Upstate Medical University

Julie Castellitto
Assistant Director

On behalf of the Department of Public Works, I am requesting that the City of Syracuse renew the agreement with SUNY Upstate Medical University for the sale of white road salt, exercising the second one (1) year extension of the four (4) available extensions. The term of this agreement shall commence with the 2023/2024 winter season.

Amend Ordinance #701-2022 to renew for the 2023/2024 winter season commencing on or about November 1, 2023 through April 30, 2024.

The rate charged to SUNY Upstate Medical University for the 2023/2024 season will include the cost to the City for purchasing white road salt of \$49.20 per ton, plus a \$5.00 administrative fee per ton, for a total of \$54.20 per ton. The City received a price of \$44.28 for the 2022/2023 season and that has gone up for the 2023/2024 season to \$49.20 per ton. Revenue from the sale of white road salt will be deposited into Revenue Account #417120.01.

Please indicate your concurrence by signing below and returning this memo to me so that I may then forward your approval to the Common Council along with the request for authorizing this legislation.

Thank you for your attention regarding this matter.



Mayor Ben Walsh
City of Syracuse, New York

10/4/23
Date

Office of Management
and Budget
233 E Washington St
Room 213
Syracuse, N.Y. 13202

Office 315 448-8252
Fax 315 448-8116

www.syr.gov

ORDINANCE AMENDING ORDINANCE NO. 653-2021 AS LAST AMENDED BY ORDINANCE NO. 702-2022 AUTHORIZING AGREEMENT BETWEEN THE CITY OF SYRACUSE AND CNY CENTRO, INC. (“CENTRO”) RELATING TO THE PROVISION OF WHITE ROAD SALT FROM THE CITY FACILITY AT THE DEPARTMENT OF PUBLIC WORKS

BE IT ORDAINED, that Ordinance No. 653-2021 as last amended by Ordinance No. 702-2022 is hereby further amended to read as follows:

WHEREAS, CNY CENTRO, Inc. (“CENTRO”) has requested that the City of Syracuse provide CENTRO with white road salt from the City Department of Public Works Facility at a cost per ton plus \$5.00 per ton administrative fee, with the base cost per ton being the City’s actual cost per ton for each year of the agreement; and

WHEREAS, the Commissioner of Public Works has recommended that said agreement be for a one-year term commencing with the 2021/2022 winter season with the option of four additional one-year renewal periods subject to the approval of the Mayor and Common Council; NOW THEREFORE,

BE IT ORDAINED, that the Mayor, on behalf of the City of Syracuse, is hereby authorized to enter into a municipal cooperation agreement with CENTRO in relation to the provision of white road salt for use by CENTRO from the City’s Department of Public Works facility at the City’s actual cost per ton, the 2021/2022 rate per ton was \$39.57, plus a \$5.00 per ton administrative fee, for a total cost of \$44.57 per ton; and

BE IT FURTHER ORDAINED, that pursuant to Ordinance No. 702-2022 the agreement with CENTRO was extended for the first one-year renewal period at the City’s actual cost per

ton, the 2022/2023 rate per ton was \$44.28 per ton, plus a \$5.00 per ton administrative fee, for a total cost of \$49.28 per ton for the first one-year renewal period; and

BE IT FURTHER ORDAINED, that the agreement with SUNY Upstate authorized herein is hereby extended for the second one-year renewal period at the City's actual cost per ton, the 2023/2024 rate per ton is \$49.20 per ton, plus a \$5.00 per ton administrative fee, for a total cost of \$54.20 per ton for the second one-year renewal period; and

BE IT FURTHER ORDAINED, that the City's Commissioner of Public Works shall administer the system to provide for coordination and scheduling of use of the facility which will accommodate the provision of white road salt for City and CENTRO; and

BE IT FURTHER ORDAINED, that CENTRO shall at all times provide its own vehicles for receipt and transportation of the white road salt; and

BE IT FURTHER ORDAINED, that the City shall not be responsible for the white road salt supply or lack thereof for reasons beyond the City's control, including but not limited to strike, white road salt shortage, or late deliveries from suppliers of white road salt; and

BE IT FURTHER ORDAINED, that the initial term of the agreement shall be for one year commencing on or about November 1, 2021 through April 30, 2022, with the option of four additional one-year renewal period subject to the approval of the Mayor and Common Council, and further that either the City or CENTRO may, notwithstanding the term of the contract, terminate this contract at any time upon thirty (30) days written notice to the other party, provided that all costs and expenses due or accruing under such agreement shall be promptly paid on or prior to the date of termination; and

BE IT FURTHER ORDAINED, that this agreement was previously extended for the first one year renewal period and is hereby extended for the second one (1) year renewal period commencing on or about November 1 2023 through April 30, 2024; and

BE IT FURTHER ORDAINED, that this amended agreement shall be subject to the necessary approvals of CENTRO and copies of the approval shall be submitted to the Corporation Counsel; and

BE IT FURTHER ORDAINED that this amended agreement shall contain such additional terms and conditions as the Corporation Counsel shall determine to be in the best interest of the City.

_____ = new material

DRAFT



25

DEPARTMENT OF PUBLIC WORKS

CITY OF SYRACUSE, MAYOR BEN WALSH

September 21, 2023

Jeremy Robinson
Commissioner

Ann Fordock
Deputy Commissioner

Martin E. Davis, L.S.
Deputy Commissioner

Ms. Patricia McBride
City Clerk
230 City Hall
Syracuse, NY 13202

Re: Request to Renew the Agreement with CNY Centro, Inc. and the City of Syracuse Department of DPW for the sale of White Road Salt

Dear Ms. McBride:

Please prepare legislation for the upcoming meeting of the common council to renew the agreement between CNY Centro, Inc. and the City of Syracuse Department of DPW for the sale of white road salt, exercising the second one (1) year extension of the four (4) available extensions. The term of this agreement shall commence with the 2023/2024 winter season.

Amend ordinance # 702-2022 to renew for the 2023/2024 winter season commencing on or about November 1, 2023 through April 30, 2024.

The rate charged to CNY Centro, Inc. for the 2023/2024 season will include the cost to the City for purchasing white road salt of \$49.20 per ton, plus a \$5.00 administrative fee per ton, for a total of \$54.20 per ton. The City received a price of \$44.28 for the 2022/2023 season and that has gone up for the 2023/2024 season to \$49.20 per ton. Revenue from the sale of white road salt will be deposited into Revenue Account #417120 01.

Should you have any questions, please do not hesitate to contact me.

Very truly yours,

Jeremy Robinson
Commissioner of Public Works

Dept. of Public Works
1200 Canal St. Extension
Syracuse, N.Y. 13202

Office 315 448-2489
Fax 315 448-8531

www.syrgov.net



OFFICE OF MANAGEMENT & BUDGET

CITY OF SYRACUSE, MAYOR BEN WALSH

Timothy M. Rudd
Director

TO: Mayor Ben Walsh
FROM: Timothy M. Rudd, Director of Management and Budget 
DATE: September 28, 2023
SUBJECT: Amend Agreement – CNY Centro, Inc.

Julie Castellitto
Assistant Director

On behalf of the Department of Public Works, I am requesting that the City of Syracuse renew the agreement with CNY Centro, Inc. for the sale of white road salt, exercising the second one (1) year extension of the four (4) available extensions. The term of this agreement shall commence with the 2023/2024 winter season.

Amend Ordinance #702-2022 to renew for the 2023/2024 winter season commencing on or about November 1, 2023 through April 30, 2024.

The rate charged to CNY Centro, Inc. for the 2023/2024 season will include the cost to the City for purchasing white road salt of \$49.20 per ton, plus a \$5.00 administrative fee per ton, for a total of \$54.20 per ton. The City received a price of \$44.28 for the 2022/2023 season and that has gone up for the 2023/2024 season to \$49.20 per ton. Revenue from the sale of white road salt will be deposited into Revenue Account #417120.01.

Please indicate your concurrence by signing below and returning this memo to me so that I may then forward your approval to the Common Council along with the request for authorizing this legislation.

Thank you for your attention regarding this matter.



Mayor Ben Walsh
City of Syracuse, New York



Date

Office of Management
and Budget
233 E Washington St
Room 213
Syracuse, N.Y. 13202

Office 315 448-8252
Fax 315 448-8116

www.syr.gov.net

Ordinance No.

2023

ORDINANCE AMENDING ORDINANCE NO. 654-2021 AS LAST AMENDED BY ORDINANCE NO. 703-2022 AUTHORIZING AN AGREEMENT BETWEEN THE CITY OF SYRACUSE AND THE SYRACUSE HOUSING AUTHORITY RELATING TO THE PROVISION OF WHITE ROAD SALT FROM THE CITY FACILITY AT THE DEPARTMENT OF PUBLIC WORKS

BE IT ORDAINED, that Ordinance No. 654-2021 as last amended by Ordinance No. 703-2022 is hereby further amended to read as follows:

WHEREAS, the Syracuse Housing Authority has requested that the City provide the Syracuse Housing Authority with white road salt from the City's Department of Public Works Facility at a cost per ton plus \$5.00 per ton administrative fee with the base cost per ton being the City's actual cost per ton for each year of the agreement; and

WHEREAS, the Commissioner of Public Works has recommended that said agreement be for a one (1) year term commencing with the 2021/2022 winter season with the option of four (4) additional one-year renewal periods subject to the approval of the Mayor and the Common Council; NOW, THEREFORE,

BE IT ORDAINED, that the Mayor, on behalf of the City of Syracuse, is hereby authorized to enter into a municipal cooperation agreement with the Syracuse Housing Authority in relation to the provision of white road salt for use by the Syracuse Housing Authority from the City's Department of Public Works facility at the City's actual cost per ton, the 2021/2022 rate per ton was \$39.57, plus a \$5.00 per ton administrative fee; at the City's actual cost per ton, the 2022/2023 rate per ton is \$44.28 per ton, plus a \$5.00 per ton administrative fee, for a total cost of \$49.28 per ton for the first one-year renewal period authorized herein; at the City's actual cost per ton, the

2023/2024 rate per ton is \$49.20 per ton, plus a \$5.00 per ton administrative fee, for a total cost of \$54.20 per ton for the second one-year renewal period authorized herein; and

BE IT FURTHER ORDAINED, that the City's Commissioner of Public Works shall administer the system so as to provide for coordination and scheduling of use of the facility which will accommodate the provision of white road salt for City and the Syracuse Housing Authority; and

BE IT FURTHER ORDAINED, that the Syracuse Housing Authority shall always provide its own vehicles for receipt and transportation of the white road salt; and

BE IT FURTHER ORDAINED, that the City shall not be responsible for the white road salt supply or lack thereof for reasons beyond the City's control, including but not limited to strike, white road salt shortage, or late deliveries from suppliers of white road salt; and

BE IT FURTHER ORDAINED, that the initial term of the agreement shall be for one (1) year commencing on or about November 1, 2021 through April 30, 2022, with the option of four (4) additional one-year renewal periods subject to the approval of the Mayor and Common Council, and further that either the City or Syracuse Housing Authority may, notwithstanding the term of the contract, terminate this contract at any time upon thirty (30) days' written notice to the other party, provided that all costs and expenses due or accruing under such agreement shall be promptly paid on or prior to the date of termination; and

BE IT FURTHER ORDAINED, that this agreement was previously extended for the first one year renewal period and is hereby extended for the second one (1) year renewal period commencing on or about November 1 2023 through April 30, 2024; and

BE IT FURTHER ORDAINED, that this amended agreement shall be subject to the necessary approvals of the Syracuse Housing Authority and copies of the approval shall be submitted to the Corporation Counsel; and

BE IT FURTHER ORDAINED that this amended agreement shall contain such additional terms and conditions as the Corporation Counsel shall determine to be in the best interest of the City.

_____ = new material

DRAFT



26

DEPARTMENT OF PUBLIC WORKS

CITY OF SYRACUSE, MAYOR BEN WALSH

September 21, 2023

Jeremy Robinson
Commissioner

Ann Fordock
Deputy Commissioner

Martin E. Davis, L.S.
Deputy Commissioner

Ms. Patricia McBride
City Clerk
230 City Hall
Syracuse, NY 13202

Re: Request to Renew the Agreement with Syracuse Housing Authority and the City of Syracuse Department of DPW for the sale of White Road Salt

Dear Ms. McBride:

Please prepare legislation for the upcoming meeting of the common council to renew the agreement between Syracuse Housing Authority and the City of Syracuse Department of DPW for the sale of white road salt, exercising the second one (1) year extension of the four (4) available extensions. The term of this agreement shall commence with the 2023/2024 winter season.

Amend ordinance # 703-2022 to renew for the 2023/2024 winter season commencing on or about November 1, 2023 through April 30, 2024.

The rate charged to Syracuse Housing Authority for the 2023/2024 season will include the cost to the City for purchasing white road salt of \$49.20 per ton, plus a \$5.00 administrative fee per ton, for a total of \$54.20 per ton. The City received a price of \$44.28 for the 2022/2023 season and that has gone up for the 2023/2024 season to \$49.20 per ton. Revenue from the sale of white road salt will be deposited into Revenue Account #417120 01.

Should you have any questions, please do not hesitate to contact me.

Very truly yours,

Jeremy Robinson
Commissioner of Public Works

Dept. of Public Works
1200 Canal St. Extension
Syracuse, N.Y. 13202

Office 315 448-2489
Fax 315 448-8531

www.syr.gov.net

9



OFFICE OF MANAGEMENT & BUDGET

CITY OF SYRACUSE, MAYOR BEN WALSH

Timothy M. Rudd
Director

Julie Castellitto
Assistant Director

TO: Mayor Ben Walsh
FROM: Timothy M. Rudd, Director of Management and Budget
DATE: September 28, 2023
SUBJECT: Amend Agreement – Syracuse Housing Authority

On behalf of the Department of Public Works, I am requesting that the City of Syracuse renew the agreement with Syracuse Housing Authority for the sale of white road salt, exercising the second one (1) year extension of the four (4) available extensions. The term of this agreement shall commence with the 2023/2024 winter season.

Amend Ordinance #703-2022 to renew for the 2023/2024 winter season commencing on or about November 1, 2023 through April 30, 2024.

The rate charged to Syracuse Housing Authority for the 2023/2024 season will include the cost to the City for purchasing white road salt of \$49.20 per ton, plus a \$5.00 administrative fee per ton, for a total of \$54.20 per ton. The City received a price of \$44.28 for the 2022/2023 season and that has gone up for the 2023/2024 season to \$49.20 per ton. Revenue from the sale of white road salt will be deposited into Revenue Account #417120.01.

Please indicate your concurrence by signing below and returning this memo to me so that I may then forward your approval to the Common Council along with the request for authorizing this legislation.

Thank you for your attention regarding this matter.



Mayor Ben Walsh
City of Syracuse, New York

10/4/23
Date

Office of Management
and Budget
233 E Washington St
Room 213
Syracuse, N.Y. 13202

Office 315 448-8252
Fax 315 448-8116

www.syr.gov

ORDINANCE AMENDING ORDINANCE NO. 625-2021 AS LAST AMENDED BY ORDINANCE NO. 704-2022 AUTHORIZING AN AGREEMENT BETWEEN THE CITY OF SYRACUSE AND THE COUNTY OF ONONDAGA COUNTY RELATIVE TO THE USE BY ONONDAGA COUNTY OF THE CITY FUEL FACILITY AT THE DEPARTMENT OF PUBLIC WORKS

BE IT ORDAINED, that Ordinance No. 625-2021 as last amended by Ordinance No.704-2022 is hereby further amended to read as follows:

WHEREAS, the County of Onondaga (“Onondaga County” or “County”) has requested permission to fuel cars and pick-up trucks owned by Onondaga County and/or used by the officers and employees of Onondaga County in the course of their employment responsibilities, at the City Department of Public Works Fuel Facility; and

WHEREAS, the Commissioner of Public Works has determined that the City Fuel Facility located at the Department of Public Works can handle the additional fuel required to carry out the terms of the agreement; and

WHEREAS, Onondaga County has agreed to reimburse the city for the cost of fuel (including compressed natural gas), plus a \$.06 administrative fee per gallon, and all costs associated with the addition of Onondaga County vehicles to the City's computerized fuel handling system including paying the charge for gas keys based on the actual cost to the City plus a five percent (5%) administrative charge for personnel identification numbers, which is necessary whenever a new or lost key is issued; NOW, THEREFORE,

BE IT ORDAINED, that the Mayor, on behalf of the City of Syracuse, is hereby authorized to enter into a municipal cooperation agreement with Onondaga County in relation to the use of

the City of Syracuse Public Works Fuel Facility by cars and pick-up trucks owned by the County of Onondaga and/or used by Onondaga County officers and employees in the course of their employment responsibilities, with (1) all the costs of vehicle gas keys and personnel identification numbers required by said County vehicles, (2) costs necessary for computer accessibility, including but not limited to a phone modem, (3) the cost of fuel used in County vehicles purchased under the appropriate City and/or County fuel contracts, plus an administrative fee of \$.06 per gallon, to be paid by the County to the City on a monthly basis for fuel costs, (4) with the charge for keys being based on actual cost to the City to be paid on an "as incurred basis" as are the charges for all identification numbers and computer accessibility costs, and (5) the City shall collect a five percent (5%) administrative charge for vehicles keys and personnel identification numbers issued to the County; such billing shall be handled through the appropriate City department or departments; and

BE IT FURTHER ORDAINED, that any updates or improvements to the City's Fuel Facility and related systems shall be a shared cost between the City and the County based on percentage of fuel (including compressed natural gas) used by each party, provided the City shall notify and get the approval of the County prior to commencement of such improvements, and further the County shall be solely responsible for the costs of updates or changes in programming which are done for the convenience of the County; and

BE IT FURTHER ORDAINED, that the City's Commissioner of Public Works shall administer the system so as to provide for coordination and scheduling of use of the facility which will accommodate the fueling of vehicles at the Fuel Facility for City and County vehicles; and

BE IT FURTHER ORDAINED, that the City shall not be responsible for the fuel supply or lack thereof for reasons beyond the City's control, including but not limited to strike, fuel shortage, or late deliveries from suppliers of fuel; and

BE IT FURTHER ORDAINED, that the initial term of the agreement shall be for one year, commencing on or about October 14, 2021, and may be renewed, with the approval of the Mayor and Common Council of the City of Syracuse and County, for two (2) additional one-year terms as determined by the parties, and further that either the City or the County may, notwithstanding the term of the contract, terminate this contract at any time upon thirty (30) days' written notice to the other party, provided that all costs and expenses due or accruing under such agreement shall be promptly paid on or prior to the date of termination; and

BE IT FURTHER ORDAINED, that this agreement was previously extended for the first one (1) year renewal period commencing on or about October 14, 2022 and is hereby extended for the second one (1) year renewal period commencing on or about October 14, 2023 through October 13, 2024 under the same terms and conditions for payment noted above; and

BE IT FURTHER ORDAINED, that this amended agreement shall be subject to the necessary approvals of the County of Onondaga, and copies of the approval shall be submitted to the Corporation Counsel; and

BE IT FURTHER ORDAINED that this amended agreement shall contain such additional terms and conditions as the Corporation Counsel shall determine to be in the best interest of the city.

_____ = new material



27

DEPARTMENT OF PUBLIC WORKS

CITY OF SYRACUSE, MAYOR BEN WALSH

September 25, 2023

Jeremy Robinson
Commissioner

Ann Fordock
Deputy Commissioner

Martin E. Davis, L.S.
Deputy Commissioner

Ms. Patricia McBride
Director of Management and Budget
City Hall Room 231
Syracuse, New York 13202

Re: Request for Renewal of the Agreement between Onondaga County and the City of Syracuse for the Use of the City's Fuel Facility

Dear Ms. McBride:

Please prepare the following legislation for the next meeting of the Common Council requesting authorization to renew the agreement between Onondaga County and the City of Syracuse for the use of the City's Fuel Facility at the Department of Public Works by Onondaga County, exercising the second and final one (1) year extension of the two (2) available extensions. This agreement will commence on October 14, 2023.

Amend Ordinance 704-2022 to renew for the first one (1) year extension for the time period October 14, 2023 – October 13, 2024.

Terms of this agreement are as follows:

1. Onondaga County will be permitted to fuel its vehicles, including cars and pick-up trucks owned by the County and/or used by Onondaga County officers and employees in the course of their employment responsibilities at the City Department of Public Works Fuel Facility.
2. Onondaga County will reimburse the City for the cost of fuel, including compressed natural gas, plus a \$.06 administrative fee per gallon, and all costs associated with the addition of Onondaga County vehicles to the City's computerized fuel handling system, including paying the charge for gas keys based on actual cost to the City plus a five-percent (5%) administrative charge for a personnel ID #, which is necessary whenever a new or lost key is issued.

Monies to be deposited into revenue account # 423010 01.

Dept. of Public Works
1200 Canal St. Extension
Syracuse, N.Y. 13202

Office 315 448-2489
Fax 315 448-8531

www.syr.gov.net

Very truly yours,

Jeremy Robinson
Commissioner of Public Works

10



OFFICE OF MANAGEMENT & BUDGET

CITY OF SYRACUSE, MAYOR BEN WALSH

Timothy M. Rudd
Director

Julie Castellitto
Assistant Director

TO: Mayor Ben Walsh
FROM: Timothy M. Rudd, Director of Management and Budget
DATE: September 28, 2023
SUBJECT: Amend Agreement – Onondaga County

On behalf of the Department of Public Works, I am requesting that the City of Syracuse renew the agreement between Onondaga County and the City of Syracuse for the use of the City's Fuel Facility at the Department of Public Works by Onondaga County, exercising the second and final one (1) year extension of the two (2) available extensions. This agreement will commence on October 14, 2023.

Amend Ordinance #704-2022 to renew the first one (1) year extension for the time period October 14, 2023 – October 13, 2024.

Terms of this agreement are as follows:

1. Onondaga County will be permitted to fuel its vehicles, including cars and pick-up trucks owned by Onondaga County and/or used by Onondaga County officers and employees in the course of their employment responsibilities at the City Department of Public Works Fuel Facility.
2. Onondaga County will reimburse the City for the cost of fuel, including compressed natural gas, plus a \$.06 administrative fee per gallon, and all costs associated with the addition of Onondaga County vehicles to the City's computerized fuel handling system, including paying the charge for gas keys based on actual cost to the City plus a five-percent (5%) administrative charge for a personnel ID #, which is necessary whenever a new or lost key is issued.

Monies to be deposited into revenue account #423010.01.

Please indicate your concurrence by signing below and returning this memo to me so that I may then forward your approval to the Common Council along with the request for authorizing this legislation.

Thank you for your attention regarding this matter.

Office of Management
and Budget
233 E Washington St
Room 213
Syracuse, N.Y. 13202

Office 315 448-8252
Fax 315 448-8116

www.syr.gov



Mayor Ben Walsh
City of Syracuse, New York

10/4/23
Date

**ORDINANCE AMENDING ORDINANCE
NO. 626-2021 AS LAST AMENDED BY
ORDINANCE NO. 705-2022 AUTHORIZING
AN AGREEMENT BETWEEN THE CITY OF
SYRACUSE AND THE SYRACUSE CITY
SCHOOL DISTRICT (“SCSD”) RELATIVE TO
THE USE BY SYRACUSE CITY SCHOOL
DISTRICT OF THE CITY FUEL FACILITY AT
THE DEPARTMENT OF PUBLIC WORKS**

BE IT ORDAINED, that Ordinance No. 626-2021 as last amended by Ordinance No. 705-2022 is hereby further amended to read as follows:

WHEREAS, the Syracuse City School District has requested permission to fuel cars and pickup trucks owned by the Syracuse City School District and/or used by Syracuse City School District officers and employees in the course of their employment responsibilities at the City Department of Public Works Fuel Facility; and

WHEREAS, the Commissioner of Public Works has determined that the City Fuel Facility located at the Department of Public Works is capable of handling the additional fuel required to carry out the terms of the agreement; and

WHEREAS, the Syracuse City School District has agreed to reimburse the City for the cost of fuel (including compressed natural gas), plus a \$.06 administrative fee per gallon, and all costs associated with the addition of Syracuse City School District vehicles to the City's computerized fuel handling system including paying the charge for gas keys based on the actual cost to the City plus a five percent (5%) administrative charge for personnel identification numbers, which is necessary whenever a new or lost key is issued; NOW, THEREFORE,

BE IT ORDAINED, that the Mayor, on behalf of the City of Syracuse, is hereby authorized to enter into a municipal cooperation agreement with the Syracuse City School District (“SCSD”)

in relation to the use of the City of Syracuse Public Works Fuel Facility by cars and pick-up trucks owned by the SCSD and/or used by SCSD officers and employees in the course of their employment responsibilities, with (1) all the costs of vehicle gas keys and personnel identification numbers required by said SCSD vehicles, (2) costs necessary for computer accessibility, including but not limited to a phone modem, (3) the cost of fuel used in SCSD vehicles purchased under the appropriate City and/or County fuel contracts, plus an administrative fee of \$.06 per gallon, to be paid by the SCSD to the City on a monthly basis for fuel costs, (4) with the charge for keys being based on actual cost to the City to be paid on an "as incurred basis" as are the charges for all identification numbers and computer accessibility costs, and (5) the City shall collect a five percent (5%) administrative charge for vehicles keys and personnel identification numbers issued to the SCSD; such billing shall be handled through the appropriate City department or departments; and

BE IT FURTHER ORDAINED, that the number of SCSD vehicles may be increased provided the Commissioner of Public Works shall determine that the City's Fuel Facility is capable of handling such additional SCSD vehicles and the costs shall be paid by the SCSD in accordance with the terms of the agreement; and

BE IT FURTHER ORDAINED, that the City's Commissioner of Public Works shall administer the system so as to provide for coordination and scheduling of use of the facility which will accommodate the fueling of vehicles at the Fuel Facility for City and SCSD vehicles; and

BE IT FURTHER ORDAINED, that the City shall not be responsible for the fuel supply or lack thereof for reasons beyond the City's control, including but not limited to strike, fuel shortage, or late deliveries from suppliers of fuel; and

BE IT FURTHER ORDAINED, that the initial term of the agreement shall be for one year, commencing on or about October 14, 2021, and may be renewed, with the approval of the Mayor

and Common Council of the City of Syracuse and SCSD, for two (2) additional one-year terms as determined by the parties, and further that either the City or the SCSD may, notwithstanding the term of the contract, terminate this contract at any time upon thirty (30) days' written notice to the other party, provided that all costs and expenses due or coming under such agreement shall be promptly paid on or prior to the date of termination; and

BE IT FURTHER ORDAINED, that this agreement was previously extended for the first one (1) year renewal period commencing on or about October 14, 2022 and is hereby extended for the second one (1) year renewal period commencing on or about October 14, 2023 through October 13, 2024 under the same terms and conditions for payment noted above; and

BE IT FURTHER ORDAINED, that this amended agreement shall be subject to the necessary approvals of the SCSD, and copies of the approval shall be submitted to the Corporation Counsel; and

BE IT FURTHER ORDAINED that this amended agreement shall contain such additional terms and conditions as the Corporation Counsel shall determine to be in the best interest of the city.

_____ = new material



28

DEPARTMENT OF PUBLIC WORKS

CITY OF SYRACUSE, MAYOR BEN WALSH

September 25, 2023

Jeremy Robinson
Commissioner

Ann Fordock
Deputy Commissioner

Martin E. Davis, L.S.
Deputy Commissioner

Ms. Patricia McBride
Director of Management and Budget
City Hall Room 231
Syracuse, New York 13202

Re: Request for Renewal of the Agreement between Syracuse City School District and the City of Syracuse for the Use of the City's Fuel Facility

Dear Ms. McBride:

Please prepare the following legislation for the next meeting of the Common Council requesting authorization to renew the agreement between Syracuse City School District and the City of Syracuse for the use of the City's Fuel Facility at the Department of Public Works by Onondaga County, exercising the second and final one (1) year extension of the two (2) available extensions. This agreement will commence on October 14, 2023.

Amend Ordinance 705-2022 to renew for the second and final one (1) year extension for the time period October 14, 2023 – October 13, 2024.

The terms of the agreement are as follows:

1. Syracuse City School District will be permitted to fuel its vehicles, including cars and pick-up trucks owned by Syracuse City School District and/or used by Syracuse City School District officers and employees in the course of their employment responsibilities at the City Department of Public Works Fuel Facility.
2. Syracuse City School District will reimburse the City for the cost of fuel, including compressed natural gas, plus a \$.06 administrative fee per gallon, and all costs associated with the addition of Syracuse City School District vehicles to the City's computerized fuel handling system, including paying the charge for gas keys based on actual cost to the City plus a five-percent (5%) administrative charge for a personnel ID #, which is necessary whenever a new or lost key is issued.

Dept. of Public Works
1200 Canal St. Extension
Syracuse, N.Y. 13202

Office 315 448-2489
Fax 315 448-8531

www.syr.gov.net

Monies to be deposited into revenue account # 549100 01 51320.

Very truly yours,

Jeremy Robinson
Commissioner of Public Works

11



OFFICE OF MANAGEMENT & BUDGET

CITY OF SYRACUSE, MAYOR BEN WALSH

Timothy M. Rudd
Director

Julie Castellitto
Assistant Director

TO: Mayor Ben Walsh
FROM: Timothy M. Rudd, Director of Management and Budget
DATE: September 28, 2023
SUBJECT: Amend Agreement – Syracuse City School District

On behalf of the Department of Public Works, I am requesting that the City of Syracuse renew the agreement between the Syracuse City School District and the City of Syracuse for the use of the City's Fuel Facility at the Department of Public Works, exercising the second and final one (1) year extension of the two (2) available extensions. This agreement will commence on October 14, 2023.

Amend Ordinance #705-2022 to renew the second and final one (1) year extension for the time period October 14, 2023 – October 13, 2024.

Terms of this agreement are as follows:

1. Syracuse City School District will be permitted to fuel its vehicles, including cars and pick-up trucks owned by Syracuse City School District and/or used by Syracuse City School District officers and employees in the course of their employment responsibilities at the City Department of Public Works Fuel Facility.
2. Syracuse City School District will reimburse the City for the cost of fuel, including compressed natural gas, plus a \$.06 administrative fee per gallon, and all costs associated with the addition of Syracuse City School District vehicles to the City's computerized fuel handling system, including paying the charge for gas keys based on actual cost to the City plus a five-percent (5%) administrative charge for a personnel ID #, which is necessary whenever a new or lost key is issued.

Monies to be deposited into revenue account #549100.01.51320.

Please indicate your concurrence by signing below and returning this memo to me so that I may then forward your approval to the Common Council along with the request for authorizing this legislation.

Thank you for your attention regarding this matter.

Office of Management
and Budget
233 E Washington St
Room 213
Syracuse, N.Y. 13202

Office 315 448-8252
Fax 315 448-8116

www.syr.gov.net

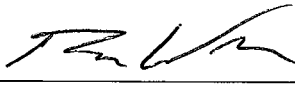

Mayor Ben Walsh
City of Syracuse, New York

10/4/23
Date

ORDINANCE AMENDING ORDINANCE NO. 627-2021 AS LAST AMENDED BY ORDINANCE NO. 706-2022 AUTHORIZING AN AGREEMENT BETWEEN THE CITY OF SYRACUSE AND THE SYRACUSE HOUSING AUTHORITY (“SHA”) RELATIVE TO THE USE BY SHA OF THE CITY FUEL FACILITY AT THE DEPARTMENT OF PUBLIC WORKS

BE IT ORDAINED, that Ordinance No. 627-2021 as last amended by Ordinance No.706-2022 is hereby further amended to read as follows:

WHEREAS, the Syracuse Housing Authority has requested permission to fuel cars and pickup trucks owned by the Syracuse Housing Authority and/or used by the Syracuse Housing Authority officers and employees in the course of their employment responsibilities at the City Department of Public Works Fuel Facility; and

WHEREAS, the Commissioner of Public Works has determined that the City Fuel Facility located at the Department of Public Works is capable of handling the additional fuel required to carry out the terms of the agreement; and

WHEREAS, the Syracuse Housing Authority has agreed to reimburse the City for the cost of fuel (including compressed natural gas), plus a \$.06 administrative fee per gallon, and all costs associated with the addition of Syracuse Housing Authority vehicles to the City's computerized fuel handling system including paying the charge for gas keys based on the actual cost to the City plus a five percent (5%) administrative charge for personnel identification numbers, which is necessary whenever a new or lost key is issued; NOW, THEREFORE,

BE IT ORDAINED, that the Mayor, on behalf of the City of Syracuse, is hereby authorized to enter into a municipal cooperation agreement with the Syracuse Housing Authority (“SHA”) in relation to the use of the City of Syracuse Public Works Fuel Facility by cars and pick-up trucks

owned by the SHA and/or used by the officers and employees in the course of their employment responsibilities, with (1) all the costs of vehicle gas keys and personnel identification numbers required by said SHA vehicles, (2) costs necessary for computer accessibility, including but not limited to a phone modem, (3) the cost of fuel used in SHA vehicles purchased under the appropriate City and/or County fuel contracts, plus an administrative fee of \$.06 per gallon, to be paid by the SHA to the City on a monthly basis for fuel costs, (4) with the charge for keys being based on actual cost to the City to be paid on an "as incurred basis" as are the charges for all identification numbers and computer accessibility costs, and (5) the City shall collect a five percent (5%) administrative charge for vehicles keys and personnel identification numbers issued to the SHA; such billing shall be handled through the appropriate City department or departments; and

BE IT FURTHER ORDAINED, that the number of SHA vehicles may be increased provided the Commissioner of Public Works shall determine that the City's Fuel Facility is capable of handling such additional SHA vehicles and the costs shall be paid by the SHA in accordance with the terms of the agreement; and

BE IT FURTHER ORDAINED, that the City's Commissioner of Public Works shall administer the system so as to provide for coordination and scheduling of use of the facility which will accommodate the fueling of vehicles at the Fuel Facility for City and SHA vehicles; and

BE IT FURTHER ORDAINED, that the City shall not be responsible for the fuel supply or lack thereof for reasons beyond the City's control, including but not limited to strike, fuel shortage, or late deliveries from suppliers of fuel; and

BE IT FURTHER ORDAINED, that the initial term of the agreement shall be for one year, commencing on or about October 14, 2021, and may be renewed, with the approval of the Mayor and Common Council of the City of Syracuse and SHA, for two (2) additional one-year terms as

determined by the parties, and further that either the City or SHA may, notwithstanding the term of the contract, terminate this contract at any time upon thirty (30) days' written notice to the other party, provided that all costs and expenses due or coming under such agreement shall be promptly paid on or prior to the date of termination; and

BE IT FURTHER ORDAINED, that this agreement was previously extended for the first one (1) year renewal period commencing on or about October 14, 2022 and is hereby extended for the second one (1) year renewal period commencing on or about October 14, 2023 through October 13, 2024 under the same terms and conditions for payment noted above; and

BE IT FURTHER ORDAINED, that this amended agreement shall be subject to the necessary approvals of SHA, and copies of the approval shall be submitted to the Corporation Counsel; and

BE IT FURTHER ORDAINED, that this amended agreement shall contain such additional terms and conditions as the Corporation Counsel shall determine to be in the best interest of the City.



21

DEPARTMENT OF PUBLIC WORKS

CITY OF SYRACUSE, MAYOR BEN WALSH

September 25, 2023

Jeremy Robinson
Commissioner

Ms. Patricia McBride
Director of Management and Budget
City Hall Room 231
Syracuse, New York 13202

Ann Fordock
Deputy Commissioner

Martin E. Davis, L.S.
Deputy Commissioner

Re: Request for Renewal of the Agreement between Syracuse Housing Authority and the City of Syracuse for the Use of the City's Fuel Facility

Dear Ms. McBride:

Please prepare the following legislation for the next meeting of the Common Council requesting authorization to renew the agreement between Syracuse Housing Authority and the City of Syracuse for the use of the City's Fuel Facility at the Department of Public Works by Onondaga County, exercising the second and final one (1) year extension of the two (2) available extensions. This agreement will commence on October 14, 2023.

Amend Ordinance 706-2022 to renew for the second and final one (1) year extension for the time period October 14, 2023 – October 13, 2024.

The terms of this agreement are as follows:

1. Syracuse Housing Authority will be permitted to fuel its vehicles, including cars and pick-up trucks owned by Syracuse Housing Authority and/or used by Syracuse Housing Authority officers and employees in the course of their employment responsibilities at the City Department of Public Works Fuel Facility.
2. Syracuse Housing Authority will reimburse the City for the cost of fuel, including compressed natural gas, plus a \$.06 administrative fee per gallon, and all costs associated with the addition of Syracuse Housing Authority vehicles to the City's computerized fuel handling system, including paying the charge for gas keys based on actual cost to the City plus a five-percent (5%) administrative charge for a personnel ID #, which is necessary whenever a new or lost key is issued.

Dept. of Public Works
1200 Canal St. Extension
Syracuse, N.Y. 13202

Monies to be deposited into revenue account # 417120 01.

Office 315 448-2489
Fax 315 448-8531

Very truly yours,

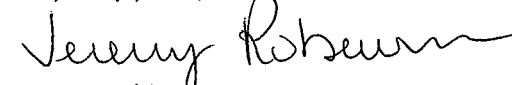
Jeremy Robinson
Commissioner of Public Works

www.syr.gov.net

12



OFFICE OF MANAGEMENT & BUDGET

CITY OF SYRACUSE, MAYOR BEN WALSH

Timothy M. Rudd
Director

TO: Mayor Ben Walsh
FROM: Timothy M. Rudd, Director of Management and Budget
DATE: September 28, 2023
SUBJECT: Amend Agreement – Syracuse Housing Authority

Julie Castellitto
Assistant Director

On behalf of the Department of Public Works, I am requesting that the City of Syracuse renew the agreement between the Syracuse Housing Authority and the City of Syracuse for the use of the City's Fuel Facility at the Department of Public Works by Onondaga County, exercising the second and final one (1) year extension of the two (2) available extensions. This agreement will commence on October 14, 2023.

Amend Ordinance #706-2022 to renew the second and final one (1) year extension for the time period October 14, 2023 – October 13, 2024.

Terms of this agreement are as follows:

1. Syracuse Housing Authority will be permitted to fuel its vehicles, including cars and pick-up trucks owned by Syracuse Housing Authority and/or used by Syracuse Housing Authority officers and employees in the course of their employment responsibilities at the City Department of Public Works Fuel Facility.
2. Syracuse Housing Authority will reimburse the City for the cost of fuel, including compressed natural gas, plus a \$.06 administrative fee per gallon, and all costs associated with the addition of Syracuse Housing Authority vehicles to the City's computerized fuel handling system, including paying the charge for gas keys based on actual cost to the City plus a five-percent (5%) administrative charge for a personnel ID #, which is necessary whenever a new or lost key is issued.

Monies to be deposited into revenue account #417120.01.

Please indicate your concurrence by signing below and returning this memo to me so that I may then forward your approval to the Common Council along with the request for authorizing this legislation.

Thank you for your attention regarding this matter.

Office of Management
and Budget
233 E Washington St
Room 213
Syracuse, N.Y. 13202

Office 315 448-8252
Fax 315 448-8116

www.syr.gov.net



Mayor Ben Walsh
City of Syracuse, New York

10/4/23
Date

Ordinance No.

2023

**ORDINANCE AUTHORIZING CONTRACT
WITH BARTON & LOGUIDICE, D.P.C.
RELATIVE TO PROVIDING ENGINEERING
SERVICES FOR THE SCOPING AND
PRELIMINARY DESIGN PHASES OF THE
ERIE BOULEVARD WEST PEDESTRIAN AND
BIKE IMPROVEMENTS PROJECT, PIN NO.
3950.80**

WHEREAS, Section 5-205-A of the Charter of the City of Syracuse, as amended, provides the Mayor shall "award contracts for professional services subject to the approval of the Common Council"; and

WHEREAS, the Mayor has approved the retention of Barton & Loguidice, D.P.C., under the following terms:

(1) Barton & Loguidice, D.P.C. shall provide all required engineering services for the Scoping and Preliminary Design Phases of the Erie Boulevard West Pedestrian and Bike Improvements Project, PIN No. 3950.80;

(2) The City shall pay to Barton & Loguidice D.P.C. a total amount not to exceed \$296,000.00 to be paid on a time-and-expense basis for all services under this agreement; NOW, THEREFORE,

BE IT ORDAINED, that the Mayor, on behalf of the City of Syracuse, be and he hereby is authorized to execute such contract, as hereinabove stated, subject to the approval of the Corporation Counsel as to terms, form and execution; and

BE IT FURTHER ORDAINED, that all costs associated with this agreement shall be charged to Capital Account No. 599807.07.80405.700395080 or another appropriate budget account as designated by the Commissioner of Finance with subsequent reimbursement of 80% of the cost from the Federal government through the Transportation Improvement Program (TIP) as previously authorized by Ordinance No. 834-2022.



30

DEPARTMENT OF ENGINEERING

CITY OF SYRACUSE, MAYOR BEN WALSH

Mary E. Robison, PE
City Engineer

29 September, 2023

John Kivlehan
Design & Construction

Ms. Patricia McBride
Office of the City Clerk
231 City Hall

Kelly Haggerty
Public Buildings

Syracuse, New York 13202

Marc Romano
Mapping & Surveying

Request to Authorize a Consultant Agreement with Barton & Loguidice, D.P.C. for the Scoping & Preliminary Design Service Fee for the Erie Boulevard West Pedestrian and Bike Improvements Project, PIN 395080.

Dear Ms. McBride:

Please prepare the following legislation for the next meeting of the Syracuse Common Council:

An Ordinance authorizing an Agreement with Barton & Loguidice, D.P.C. for an amount not to exceed \$296,000.00 to be paid on a time and expense basis for all services required to produce scoping and preliminary design plans for the Erie Boulevard West Pedestrian and Bike Improvements Project, PIN 395080.

This project is being funded 80% with federal funds, and 20% with existing local capital account funds previously authorized by Ordinance No. 834 of 2022. Costs will be charged to Capital Account No. 599807.07.80405.700395080.

The selection of the consultant was completed following the federal and state procedures for professional services and in accordance with the City's RFQ procedures. The RFQ Committee made the recommendation of Barton & Loguidice, D.P.C. to the Mayor, and the Mayor approved of the selection of Barton & Loguidice, D.P.C. Per the attached memorandum, the Mayor further approved the not-to-exceed fee.

Please let me know if you have any questions related to this request.

Very Truly Yours,

Mary E. Robison, P.E.,
City Engineer

Dept. of Engineering
233 E. Washington St.
City Hall, Room 401
Syracuse, N.Y. 13202
Office 315 448-8200
Fax 315 448-8488

www.syr.gov.net

16



DEPARTMENT OF ENGINEERING

CITY OF SYRACUSE, MAYOR BEN WALSH

Mary E. Robison, PE
City Engineer

John Kivlehan
Design & Construction

Kelly Haggerty
Public Buildings

Marc Romano
Mapping & Surveying

TO: Ben Walsh, Mayor

ATTN: Tim Rudd, Budget Director, Office of Management and Budget *ae*

FROM: Mary Robison, P.E., City Engineer

DATE: 29 September, 2023

RE: Memorandum of Approval – Barton & Loguidice, D.P.C. Scoping & Preliminary Design Service Fee for the Erie Boulevard West Pedestrian and Bike Improvements Project, PIN 395080.

You approved the selection of Barton & Loguidice, D.P.C. for the scoping & preliminary design of the Erie Boulevard West Pedestrian and Bike Improvements Project, PIN 395080. We have now completed negotiations regarding the scope of services and not to exceed fee with Barton & Loguidice, D.P.C. for Scoping & Preliminary Design.

We have negotiated an estimated maximum total cost not to exceed \$296,000.00 for Barton & Loguidice, D.P.C. to complete the Scoping & Preliminary Design of this project as detailed in their scope of services. We will negotiate a fee for Detailed Design services with Barton & Loguidice, D.P.C. once the scoping & preliminary design process is complete. This will require amending this agreement at a later date.

Please advise if you approve Barton & Loguidice, D.P.C. proposed total maximum fee not to exceed \$296,000.00 for Erie Boulevard West Pedestrian and Bike Improvements Project, PIN 395080. Upon your approval of the fee, we will present this to the Common Council for its approval.

YES

NO

Comments: _____

Dept. of Engineering
233 E. Washington St.
City Hall, Room 401
Syracuse, N.Y. 13202
Office 315 448-8200
Fax 315 448-8488

Signature: *Ben Walsh*

Date: 10/4/23

www.syr.gov.net

Please return document to John Kivlehan, Department of Engineering

Ordinance No.

2023

ORDINANCE AUTHORIZING CONTRACT WITH BARTON & LOGUIDICE, D.P.C. RELATIVE TO PROVIDING ENGINEERING SERVICES FOR THE SCOPING AND PRELIMINARY DESIGN PHASES OF THE KIRK PARK PEDESTRIAN BRIDGE REPLACEMENT PROJECT, PIN NO. 3950.79

WHEREAS, Section 5-205-A of the Charter of the City of Syracuse, as amended, provides the Mayor shall "award contracts for professional services subject to the approval of the Common Council"; and

WHEREAS, the Mayor has approved the retention of Barton & Loguidice, D.P.C., under the following terms:

(1) Barton & Loguidice, D.P.C. shall provide all required engineering services for the Scoping and Preliminary Design Phases of the Kirk Park Pedestrian Bridge Replacement Project, PIN No. 3950.79;

(2) The City shall pay to Barton & Loguidice D.P.C. a total amount not to exceed \$183,750.00 to be paid on a time-and-expense basis for all services under this agreement; NOW, THEREFORE,

BE IT ORDAINED, that the Mayor, on behalf of the City of Syracuse, be and he hereby is authorized to execute such contract, as hereinabove stated, subject to the approval of the Corporation Counsel as to terms, form and execution; and

BE IT FURTHER ORDAINED, that all costs associated with this agreement shall be charged to Capital Account No. 599807.07.80405.700395079 or another appropriate budget account as designated by the Commissioner of Finance with subsequent reimbursement of 80% of the cost from the Federal government through the Transportation Improvement Program (TIP) as previously authorized by Ordinance No. 831-2022.



31

DEPARTMENT OF ENGINEERING

CITY OF SYRACUSE, MAYOR BEN WALSH

Mary E. Robison, PE
City Engineer

29 September, 2023

John Kivlehan
Design & Construction

Ms. Patricia McBride
Office of the City Clerk
231 City Hall
Syracuse, New York 13202

Kelly Haggerty
Public Buildings

Marc Romano
Mapping & Surveying

Request to Authorize a Consultant Agreement with Barton & Loguidice, D.P.C. for the Scoping & Preliminary Design Service Fee for the Kirk Park Pedestrian Bridge Replacement Project, PIN 395079.

Dear Ms. McBride:

Please prepare the following legislation for the next meeting of the Syracuse Common Council:

An Ordinance authorizing an Agreement with Barton & Loguidice, D.P.C. for an amount not to exceed \$183,750.00 to be paid on a time and expense basis for all services required to produce scoping and preliminary design plans for the Kirk Park Pedestrian Bridge Replacement Project, PIN 395079

This project is being funded 80% with federal funds, and 20% with existing local capital account funds previously authorized by Ordinance No. 831 of 2022. Costs will be charged to Capital Account No. 599807.07.80405.700395079.

The selection of the consultant was completed following the federal and state procedures for professional services and in accordance with the City's RFQ procedures. The RFQ Committee made the recommendation of Barton & Loguidice, D.P.C. to the Mayor, and the Mayor approved of the selection of Barton & Loguidice, D.P.C. Per the attached memorandum, the Mayor further approved the not-to-exceed fee.

Please let me know if you have any questions related to this request.

Very Truly Yours,

Mary E. Robison, P.E.,
City Engineer

Dept. of Engineering
233 E. Washington St.
City Hall, Room 401
Syracuse, N.Y. 13202
Office 315 448-8200
Fax 315 448-8488

www.syr.gov.net

17



DEPARTMENT OF ENGINEERING

CITY OF SYRACUSE, MAYOR BEN WALSH

Mary E. Robison, PE
City Engineer

John Kivlehan
Design & Construction

Kelly Haggerty
Public Buildings

Marc Romano
Mapping & Surveying

TO: Ben Walsh, Mayor

ATTN: Tim Rudd, Budget Director, Office of Management and Budget

ac

FROM: Mary Robison, P.E., City Engineer *Mary E. Robison*

DATE: 29 September, 2023

RE: Memorandum of Approval – Barton & Loguidice, D.P.C. Scoping & Preliminary Design Service Fee for the Kirk Park Pedestrian Bridge Replacement Project, PIN 395079.

You approved the selection of Barton & Loguidice, D.P.C. for the scoping & preliminary design of the Kirk Park Pedestrian Bridge Replacement Project, PIN 395079. We have now completed negotiations regarding the scope of services and not to exceed fee with Barton & Loguidice, D.P.C. for Scoping & Preliminary Design.

We have negotiated an estimated maximum total cost not to exceed \$183,750.00 for Barton & Loguidice, D.P.C. to complete the Scoping & Preliminary Design of this project as detailed in their scope of services. We will negotiate a fee for Detailed Design services with Barton & Loguidice, D.P.C. once the scoping & preliminary design process is complete. This will require amending this agreement at a later date.

Please advise if you approve Barton & Loguidice, D.P.C. proposed total maximum fee not to exceed \$183,750.00 for Kirk Park Pedestrian Bridge Replacement Project, PIN 395079. Upon your approval of the fee, we will present this to the Common Council for its approval.

YES NO

Comments: _____

Dept. of Engineering
233 E. Washington St.
City Hall, Room 401
Syracuse, N.Y. 13202
Office 315 448-8200
Fax 315 448-8488

Signature: *[Handwritten Signature]*

Date: *10/4/23*

Please return document to John Kivlehan, Department of Engineering

www.syr.gov.net



DEPARTMENT OF ENGINEERING

CITY OF SYRACUSE, MAYOR BEN WALSH

32

29 September 2023

Mary E. Robison, PE
City Engineer

John Kivlehan
Design & Construction

Kelly Haggerty
Public Buildings

Marc Romano
Mapping & Surveying

Ms. Patricia McBride
Office of the City Clerk
231 City Hall
Syracuse, New York 13202

Request for Legislation: An Ordinance Authorizing the Issuance and Sale of Bonds to Provide Funds for the Scoping, Preliminary & Detailed Design Phases of the Rt 175 over Onondaga Creek Bridge Rehabilitation Project, PIN 375719.

Dear Ms. McBride:

Please prepare the following legislation for the next meeting of the Syracuse Common Council:

An Ordinance Authorizing the Issuance and Sale of Bonds to Provide Funds for the Scoping, Preliminary & Detailed Design Phases of the Rt 175 over Onondaga Creek Bridge Rehabilitation Project, PIN 375719 for a total amount not to exceed \$315,000.00 (location also known as South Ave. over Onondaga Creek at Kirk Park). Of this amount, the City cost will be \$15,750.00 from local share bonds and \$299,250.00 will come from federal aid reimbursement.

The City is expected to incur all initial costs for this project, with subsequent 95% reimbursement from the Federal government through the Transportation Improvement Program (TIP). In accordance with Bridge NY funds; the City of Syracuse is responsible for all excess costs which exceed the amount of Bridge NY funding appropriated & construction of the project shall begin no later than twenty-four (24) months after award, and the construction phase of the project shall be completed within thirty (30) months.

Account number to be designated by the Commissioner of Finance.

Please let me know if you have any questions relative to this request.

Very Truly Yours,

Mary E. Robison, P.E.,
City Engineer

Dept. of Engineering
233 E. Washington St.
City Hall, Room 401
Syracuse, N.Y. 13202
Office 315 448-8200
Fax 315 448-8488

www.syr.gov.net

18



City of Syracuse

AUTHORIZATION TO PROCEED WITH CIP PROJECT

Date:	09/29/23	Department:	Engineering
Project Name:	Rt 175 over Onondaga Creek Bridge Rehabilitation Project, PIN 375719.		
Project Cost:	\$315,000.00		
Contact Name:	Mary E. Robison		
Project Description:	Bridge Rehab - South Ave (Rt 175) over Onondaga Creek at Kirk Park		

Projected Time Line & Funding Source(s)

Estimated Start Date: Winter 2023/2024 Estimated Completion Date: F Fall 2025

Funding Source:	Dollar Amount:
Local Share: Cash Capital	
Local Share: Bonds (complete schedule below)	\$ 15,750.00
State Aid/Grant (identify) Marchiselli	\$ -
Federal Aid/Grant (identify) TIP Funding Reimbursement	\$ 299,250.00
Other (identify)	
Other (identify)	
Total Project Funding (must equal cost):\$	
	315,000.00

Estimated Project Borrowing Timeline

Year	Fiscal Year	Estimated Amount to Borrow
1	2024	\$ 315,000.00
2		
3		
4		
5		
Total Estimated Amount to Borrow (if different than "Local Share: Bonds" above, explain)		\$ 315,000.00

The City is expected to incur all initial costs for this project with subsequent 95% reimbursement from the Federal government through the Transportation Improvement Program (TIP).

Approval to proceed with request for legislation is hereby granted.

Project in CIP Plan: Yes No Reason("No"):
of the CIP.

\$150,000 Preliminary Design is in '23/24 & \$150,000 Detailed Design is in '24/25. 95% Reimbursement vs. 80% shown in CIP.

Director of Administration: [Signature] Date: _____

Director of Management & Budget: [Signature] Date: 10/2/23

Commissioner of Finance: [Signature] Date: 10/3/23

Ordinance No.

2023

ORDINANCE AUTHORIZING AN AGREEMENT WITH THE NEW YORK STATE DEPARTMENT OF TRANSPORTATION RELATIVE TO FUNDING FOR THE SCOPING, PRELIMINARY DESIGN, AND DETAILED DESIGN PHASES OF THE ROUTE 175 OVER ONONDAGA CREEK BRIDGE REHABILITATION PROJECT, PIN NO. 3757.19 (LOCATION ALSO KNOWN AS SOUTH AVENUE OVER ONONDAGA CREEK AT KIRK PARK)

WHEREAS, the City Engineer has requested legislation authorizing the Mayor to enter into an agreement with the New York State Department of Transportation (NYSDOT) relative to funding for the scoping, preliminary design and detailed design phases of the Route 175 over Onondaga Creek Bridge Rehabilitation Project, PIN No. 3757.19 (location also known as South Avenue over Onondaga Creek at Kirk Park) (hereinafter referred to as the "Project") at a cost not to exceed \$315,000 to be initially funded with bond proceeds with repayment expected to be funded 95% from Federal funds (Transportation Improvement Program) and 5% from local funds; NOW, THEREFORE,

BE IT ORDAINED, subject to the approval of the Mayor, that the Mayor be and he is hereby authorized to enter into an agreement with the New York State Department of Transportation relative to funding for the scoping, preliminary design, and detailed design phases of the Project at a cost not to exceed \$315,000; and

BE IT FURTHER ORDAINED, that said agreement shall contain such other terms and conditions as the Corporation Counsel shall deem in the best interest of the City of Syracuse; and

BE IT FURTHER ORDAINED, that the Common Council hereby authorizes the City of Syracuse to pay in the first instance the full Federal and non-federal share of the cost of the scoping, preliminary design, and detailed design phases for the Project or portions thereof, if necessary; and

BE IT FURTHER ORDAINED, that the Mayor of the City of Syracuse be and is hereby authorized to execute all necessary Agreements, certifications or reimbursement requests on behalf of the City of Syracuse with the NYSDOT in connection with the advancement or approval of the Project and providing for the administration of the Project and the municipality's first instance funding of the non-federal share of Project costs and permanent funding of the local share of federal-aid and state-aid eligible Project costs and all Project costs within appropriations therefore that are not so eligible, if necessary; and

BE IT FURTHER ORDAINED, that a certified copy of this Ordinance be filed with the New York State Commissioner of Transportation by attaching it to any necessary Agreement in connection with the Project; and

BE IT FURTHER ORDAINED, that this Ordinance shall take effect immediately.



DEPARTMENT OF ENGINEERING

CITY OF SYRACUSE, MAYOR BEN WALSH

29 September 2023

Mary E. Robison, PE
City Engineer

John Kivlehan
Design & Construction

Kelly Haggerty
Public Buildings

Marc Romano
Mapping & Surveying

Ms. Patricia McBride
Office of the City Clerk
231 City Hall
Syracuse, New York 13202

Request for Legislation: An Ordinance Authorizing the Mayor to enter into an Agreement with the New York State Department of Transportation for the Scoping, Preliminary & Detailed Design Phases of the Rt 175 over Onondaga Creek Bridge Rehabilitation Project, PIN 375719.

Dear Ms. McBride:

Please prepare the following legislation for the next meeting of the Syracuse Common Council:

An Ordinance Authorizing the Mayor to enter into an Agreement with the New York State Department of Transportation for the Scoping, Preliminary & Detailed Design Phases of the Rt 175 over Onondaga Creek Bridge Rehabilitation Project, PIN 375719 for a total amount not to exceed \$315,000.00 (location also known as South Ave. over Onondaga Creek at Kirk Park). Of this amount, the City cost will be \$15,750.00 from local share bonds and \$299,250.00 will come from federal aid reimbursement.

The City is expected to incur all initial costs for this project, with subsequent 95% reimbursement from the Federal government through the Transportation Improvement Program (TIP). In accordance with Bridge NY funds; the City of Syracuse is responsible for all excess costs which exceed the amount of Bridge NY funding appropriated & construction of the project shall begin no later than twenty-four (24) months after award, and the construction phase of the project shall be completed within thirty (30) months.

Account number to be designated by the Commissioner of Finance.

Please let me know if you have any questions relative to this request.

Very Truly Yours,

Mary E. Robison, P.E.,
City Engineer

Dept. of Engineering
233 E. Washington St.
City Hall, Room 401
Syracuse, N.Y. 13202
Office 315 448-8200
Fax 315 448-8488

www.syr.gov.net



3A

DEPARTMENT OF ENGINEERING

CITY OF SYRACUSE, MAYOR BEN WALSH

29 September 2023

Mary E. Robison, PE
City Engineer

John Kivlehan
Design & Construction

Kelly Haggerty
Public Buildings

Marc Romano
Mapping & Surveying

Ms. Patricia McBride
Office of the City Clerk
231 City Hall
Syracuse, New York 13202

Request for Legislation: An Ordinance Authorizing the Scoping, Preliminary & Detailed Design Phases of the Design Phases of the Rt 175 over Onondaga Creek Bridge Rehabilitation Project, PIN 375719.

Dear Ms. McBride:

Please prepare the following legislation for the next meeting of the Syracuse Common Council:

An Ordinance Authorizing the Scoping, Preliminary & Detailed Design Phases of the Rt 175 over Onondaga Creek Bridge Rehabilitation Project, PIN 375719 for a total amount not to exceed \$315,000.00 (location also known as South Ave. over Onondaga Creek at Kirk Park). Of this amount, the City cost will be \$15,750.00 from local share bonds and \$299,250.00 will come from federal aid reimbursement.

The City is expected to incur all initial costs for this project, with subsequent 95% reimbursement from the Federal government through the Transportation Improvement Program (TIP). In accordance with Bridge NY funds; the City of Syracuse is responsible for all excess costs which exceed the amount of Bridge NY funding appropriated & construction of the project shall begin no later than twenty-four (24) months after award, and the construction phase of the project shall be completed within thirty (30) months.

Account number to be designated by the Commissioner of Finance.

Please let me know if you have any questions relative to this request.

Very Truly Yours,

Handwritten signature of Mary E. Robison.

Mary E. Robison, P.E.,
City Engineer

Dept. of Engineering
233 E. Washington St.
City Hall, Room 401
Syracuse, N.Y. 13202
Office 315 448-8200
Fax 315 448-8488

www.syr.gov.net



OFFICE OF MANAGEMENT & BUDGET

CITY OF SYRACUSE, MAYOR BEN WALSH

Timothy M. Rudd
Director

TO: Mayor Ben Walsh
FROM: Julie Castellitto, Assistant Director of Management and Budget *AK*
DATE: October 2, 2023
SUBJECT: Agreement – New York State Department of Transportation

Julie Castellitto
Assistant Director

On behalf of the Department of Engineering, I am requesting that the City of Syracuse authorize permission to enter into an Agreement with the New York State Department of Transportation for the Scoping, Preliminary & Detailed Design Phases of the Rt 175 over Onondaga Creek Bridge Rehabilitation Project, PIN 375719 for a total amount not to exceed \$315,000.00 (location also known as South Ave. over Onondaga Creek at Kirk Park). Of this amount, the City cost will be \$15,750.00 from local share bonds and \$299,250.00 will come from federal aid reimbursement.

The City is expected to incur all initial costs for this project, with subsequent 95% reimbursement from the Federal government through the Transportation Improvement Program (TIP). In accordance with Bridge NY funds; the City of Syracuse is responsible for all excess costs which exceed the amount of Bridge NY funding appropriated & construction of the project shall begin no later than twenty-four (24) months after award, and the construction phase of the project shall be completed within thirty (30) months.

Account number to be designated by the Commissioner of Finance.

Please indicate your concurrence by signing below and returning this memo to me so that I may then forward your approval to the Common Council along with the request for authorizing this legislation.

Thank you for your attention regarding this matter.



Mayor Ben Walsh
City of Syracuse, New York

10/4/23
Date

Office of Management
and Budget
233 E Washington St
Room 213
Syracuse, N.Y. 13202

Office 315 448-8252
Fax 315 448-8116

www.syr.gov.net



35

DEPARTMENT OF ENGINEERING

CITY OF SYRACUSE, MAYOR BEN WALSH

28 September 2023

Ms. Patricia K. McBride
Office of the City Clerk
233 E. Washington Street, Room 231
Syracuse, N.Y. 13202

Mary E. Robison, PE
City Engineer

John Kivlehan
Design and Construction

Kelly Haggerty
Public Buildings

Marc Romano
Mapping and
Surveying

Request for Legislation: Authorize a Temporary Access Agreement with Onondaga County to close S. Warren Street between S. Salina Street (north of the Salvation Army driveway) to E. Adams Street and Billings Park to use this area as a staging area for the STEAM School Construction Project

Dear Ms. McBride:

I request the following legislation for the next meeting of the Common Council be prepared:

Authorize a Temporary Access Agreement with Onondaga County to close S. Warren Street between S. Salina Street (north of the Salvation Army driveway) to E. Adams Street and Billings Park to use this area as a staging area for the STEAM School Construction Project.

This department has reviewed, coordinated with other City departments and is of the opinion that this street and park closure to vehicular and pedestrian traffic, will not interfere with the public use of the streets or emergency access to adjacent properties. It is therefore, recommended for consideration by the Common Council to authorize a temporary access agreement with **Onondaga County**, allowing the closure of S. Warren Street between S. Salina Street (north of the Salvation Army driveway) to E. Adams Street and Billings Park until August 31, 2025.

The temporary access agreement for the **closure of S. Warren Street between S. Salina Street (north of the Salvation Army driveway) to E. Adams Street and Billings Park** will contain the following provisions:

1. Onondaga County and/or its officers, representatives, agents, employees, contractors or their subcontractors are hereby authorized and permitted to enter upon CITY-owned property located in the City of Syracuse in the area of S. Warren Street between S. Salina Street (north of the Salvation Army driveway) to E. Adams Street and Billings Park as shown on the attached map for the purpose of a construction staging area for the STEAM School Construction Project.

Department of Engineering
233 E. Washington St.
City Hall, Room 401
Syracuse, N.Y. 13202
Office 315 448-8200
Fax 315 448-8488

www.syr.gov.net

15

2. The term of this agreement shall be from the date of execution by both parties until August 31, 2025.
3. The access of Onondaga County on, and over the property of the City of Syracuse shall be expressly for work associated with the staging area needed for the STEAM School Construction Project.
4. Access to the Salvation Army driveway on S. Warren Street shall be maintained at all times.
5. A clear 3-foot space must be maintained around the circumference of any fire hydrant within or adjacent to the designated use area.
6. Where security gates are installed for site access, the Chief of the Syracuse Fire Department must approve the mechanism for securing these gates and be provided access for emergency response. The security gates shall be maintained operational at all times. The Syracuse Fire Department will require immediate notification when site access has been altered or the locking mechanisms for the security gates have been changed.
7. A Manual of Uniform Traffic Control Devices (MUTCD) compliant Work Zone Traffic Control (WZTC) Plan shall be submitted to the City of Syracuse for review and approval. All appropriate vehicle and pedestrian detour signage and barriers shall be installed and maintained by Onondaga County as necessary and at all times during the road and park closure.
8. Onondaga County agrees to the extent permitted by law, to indemnify and hold harmless the City of Syracuse, its officers, agents and employees from and against all claims, damages, losses, expenses and liability of any kind, for personal injury or property damage arising from any wrongful or negligent act or omission, on the part of the County, its contractors or subcontractors, in connection with the performance of the project work and this agreement.
9. The road and park closure and any improvements and utility connections to City owned infrastructure shall be subject to the street right-of-way permitting process administered by the Commissioner of Public Works and any other standard permitting processes that exist.
10. Onondaga County shall advise the City Engineer and the Commissioner of Public Works and Centro at least two weeks in advance of when the street is going to be closed.
11. A dust and sediment and erosion control program shall be in effect for the duration of the project to prevent a nuisance and to prevent interference with or damage to the park and adjacent property, streets, sewers and drainage courses. Catch basins in S. Warren Street shall be properly protected to prevent sediment and debris from entering the sewer system.
12. That Onondaga County shall adequately and properly protect all infrastructure and park amenities including, but not limited to, park furniture, monuments, lighting, fire hydrant, existing

underground utilities located within or near said installation. If any such property or facilities are interfered with or damaged, Onondaga County, or its successors and assigns, shall be responsible for replacement to the satisfaction of the City Engineer, the Commissioner of Parks and the Commissioner of Public Works.

13. Onondaga County shall cause any insurance provided by its contractors working on the STEAM School Project, to also name the City of Syracuse as an additional insured with minimum limits of not less than two million dollars (\$2,000,000) Combined Single Limit for Bodily Injury and Property Damage. In addition, the County shall require the contractors to maintain workers compensation insurance. A Certificate of said insurance, along with the declaration page or blanket endorsement confirming the City of Syracuse as an additional insured shall be submitted to the City Engineer, Department of Engineering, Room 401 City Hall, 233 E. Washington Street, Syracuse, NY 13202.)
14. The Onondaga County shall not assign, transfer, convey, subcontract or otherwise dispose of its rights under this agreement without first obtaining the written approval of the City of Syracuse.
15. That Onondaga County, its successors, assigns, and agents shall agree that the City of Syracuse, acting through its City Engineer shall have the authority to request any on site investigations during the street and park closure to ensure that there is no damage to City property.
16. Upon completion of the street and park closure, the street right-of-way and park area shall be restored in accordance with all City of Syracuse standards and all ADA regulations to its original or better condition and shall be in conformance with all ADA regulations. S. Warren St. was last milled and paved in 2021; any damage to the pavement as determined by the City Engineer will result in Onondaga County repairing the road to the satisfaction of the City Engineer up to and including milling and paving the entire section of closed roadway. The City Engineer shall have the final determination on the limits of the required repair, without exception. The City Engineer, the Commissioner of Parks and Recreation and the Commissioner of Public works shall inspect and approve the final restoration of the road Right- of- Way and park closure.
17. This agreement shall be governed by and interpreted pursuant to the laws of the State of New York.
18. This agreement represents the entire and integrated agreement between the Onondaga County and the City of Syracuse and supersedes all prior negotiations, representations or agreements either written or oral on matters covered herein.
19. This agreement may be amended only by written instrument signed by both Onondaga County and the City of Syracuse.
20. This agreement shall become effective on the date it is signed by the parties.

Additional terms and conditions, as recommended by the City Engineer and the Corporation Counsel, shall be set forth in the Ordinance.

Sincerely,

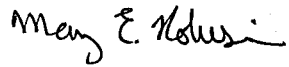

Mary E. Robison, P.E.
City Engineer

DRAFT



OFFICE OF MANAGEMENT & BUDGET

CITY OF SYRACUSE, MAYOR BEN WALSH

Timothy M. Rudd
Director

TO: Mayor Ben Walsh
FROM: Julie Castellitto, Assistant Director of Management and Budget *ac*
DATE: October 2, 2023
SUBJECT: Access Agreement – Onondaga County

Julie Castellitto
Assistant Director

On behalf of the Department of Engineering, I am requesting that the City of Syracuse authorize permission to enter a Temporary Access Agreement with Onondaga County to close S. Warren Street between S. Salina Street (north of the Salvation Army driveway) to E. Adams Street and Billings Park to use this area as a staging area for the STEAM School Construction Project.

The Department of Engineering has reviewed, coordinated with other City departments and is of the opinion that this street and park closure to vehicular and pedestrian traffic, will not interfere with the public use of the streets or emergency access to adjacent properties. It is therefore, recommended for consideration by the Common Council to authorize a temporary access agreement with **Onondaga County**, allowing the closure of S. Warren Street between S. Salina Street (north of the Salvation Army driveway) to E. Adams Street and Billings Park until August 31, 2025.

The temporary access agreement for the **closure of S. Warren Street between S. Salina Street (north of the Salvation Army driveway) to E. Adams Street and Billings Park** will contain the following provisions:

1. Onondaga County and/or its officers, representatives, agents, employees, contractors or their subcontractors are hereby authorized and permitted to enter upon CITY owned property located in the City of Syracuse in the area of S. Warren Street between S. Salina Street (north of the Salvation Army driveway) to E. Adams Street and Billings Park as shown on the attached map for the purpose of a construction staging area for the STEAM School Construction Project.
2. The term of this agreement shall be from the date of execution by both parties until August 31, 2025.
3. The access of Onondaga County on, and over the property of the City of Syracuse shall be expressly for work associated with the staging area needed for the STEAM School Construction Project.
4. Access to the Salvation Army driveway on S. Warren Street shall be maintained at all times.
5. A clear 3-foot space must be maintained around the circumference of any fire hydrant within or adjacent to the designated use area.

Office of Management
and Budget
233 E Washington St
Room 213
Syracuse, N.Y. 13202

Office 315 448-8252
Fax 315 448-8116

www.syr.gov

6. Where security gates are installed for site access, the Chief of the Syracuse Fire Department must approve the mechanism for securing these gates and be provided access for emergency response. The security gates shall be maintained operational at all times. The Syracuse Fire Department will require immediate notification when site access has been altered or the locking mechanisms for the security gates have been changed.
7. A Manual of Uniform Traffic Control Devices (MUTCD) compliant Work Zone Traffic Control (WZTC) Plan shall be submitted to the City of Syracuse for review and approval. All appropriate vehicle and pedestrian detour signage and barriers shall be installed and maintained by Onondaga County as necessary and at all times during the road and park closure.
8. Onondaga County agrees to the extent permitted by law, to indemnify and hold harmless the City of Syracuse, its officers, agents and employees from and against all claims, damages, losses, expenses and liability of any kind, for personal injury or property damage arising from any wrongful or negligent act or omission, on the part of the County, its contractors or subcontractors, in connection with the performance of the project work and this agreement.
9. The road and park closure and any improvements and utility connections to City owned infrastructure shall be subject to the street right-of-way permitting process administered by the Commissioner of Public Works and any other standard permitting processes that exist.
10. Onondaga County shall advise the City Engineer and the Commissioner of Public Works and Centro at least two weeks in advance of when the street is going to be closed.
11. A dust and sediment and erosion control program shall be in effect for the duration of the project to prevent a nuisance and to prevent interference with or damage to the park and adjacent property, streets, sewers and drainage courses. Catch basins in S. Warren Street shall be properly protected to prevent sediment and debris from entering the sewer system.
12. That Onondaga County shall adequately and properly protect all infrastructure and park amenities including, but not limited to, park furniture, monuments, lighting, fire hydrant, existing underground utilities located within or near said installation. If any such property or facilities are interfered with or damaged, Onondaga County, or its successors and assigns, shall be responsible for replacement to the satisfaction of the City Engineer, the Commissioner of Parks and the Commissioner of Public Works.
13. Onondaga County shall cause any insurance provided by its contractors working on the STEAM School Project, to also name the City of Syracuse as an additional insured with minimum limits of not less than two million dollars (\$2,000,000) Combined Single Limit for Bodily Injury and Property Damage. In addition, the County shall require the contractors to maintain workers compensation insurance. A Certificate of said insurance,

along with the declaration page or blanket endorsement confirming the City of Syracuse as an additional insured shall be submitted to the City Engineer, Department of Engineering, Room 401 City Hall, 233 E. Washington Street, Syracuse, NY 13202.)

14. The Onondaga County shall not assign, transfer, convey, subcontract or otherwise dispose of its rights under this agreement without first obtaining the written approval of the City of Syracuse.
15. That Onondaga County, its successors, assigns, and agents shall agree that the City of Syracuse, acting through its City Engineer shall have the authority to request any on site investigations during the street and park closure to ensure that there is no damage to City property.
16. Upon completion of the street and park closure, the street right-of-way and park area shall be restored in accordance with all City of Syracuse standards and all ADA regulations to its original or better condition and shall be in conformance with all ADA regulations. S. Warren St. was last milled and paved in 2021; any damage to the pavement as determined by the City Engineer will result in Onondaga County repairing the road to the satisfaction of the City Engineer up to and including milling and paving the entire section of closed roadway. The City Engineer shall have the final determination on the limits of the required repair, without exception. The City Engineer, the Commissioner of Parks and Recreation and the Commissioner of Public works shall inspect and approve the final restoration of the road Right- of- Way and park closure.
17. This agreement shall be governed by and interpreted pursuant to the laws of the State of New York.
18. This agreement represents the entire and integrated agreement between the Onondaga County and the City of Syracuse and supersedes all prior negotiations, representations or agreements either written or oral on matters covered herein.
19. This agreement may be amended only by written instrument signed by both Onondaga County and the City of Syracuse.
20. This agreement shall become effective on the date it is signed by the parties.

Additional terms and conditions, as recommended by the City Engineer and the Corporation Counsel, shall be set forth in the Ordinance.

Please indicate your concurrence by signing below and returning this memo to me so that I may then forward your approval to the Common Council along with the request for authorizing this legislation.

Thank you for your attention regarding this matter.

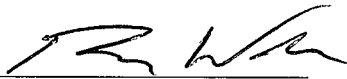

Mayor Ben Walsh
City of Syracuse, New York

10/4/23
Date

DRAFT

Request for Legislation: Authorize a Temporary Access Agreement with Onondaga County to close S. Warren Street between S. Salina Street (north of the Salvation Army driveway) to E. Adams Street and Billings Park to use this area as a staging area for the STEAM School Construction Project

Location Map:

Billings Park and S. Warren Street Temporary Closure





DEPARTMENT OF NEIGHBORHOOD & BUSINESS DEVELOPMENT

36

CITY OF SYRACUSE, MAYOR BEN WALSH

September 29, 2023

Patricia McBride, City Clerk
Office of the City Clerk
Room 231, City Hall
Syracuse, NY 13202

Commissioner
Michael Collins

**Deputy Commissioner of
Neighborhood
Development**
Michelle Sczpanski

**Deputy Commissioner of
Business Development**
Eric Ennis

Re: Legislation Request – Amend Ordinance #728-2022 – Syracuse Business Growth Accelerator Program –Upstate Minority Economic Alliance (UMEA).

Dear Ms. McBride,

Please prepare the legislation to amend Ordinance #728-2022 in order to extend a contract agreement with the Upstate Minority Economic Alliance (UMEA) through March 31, 2024. UMEA is a sub-grantee in the amount of \$70,000 as part of the Business Growth Accelerator Program. NYS Empire State Development has awarded funds to the City of Syracuse to implement a Business Growth Accelerator (BGA) program in the Central New York and Mohawk Valley regions of the state. There is no change in the contract award amount.

The purpose of the BGA is to deliver a business development program for up to twenty (20) current NYS-certified MWBE firms.

The grant period will now extend through March 31, 2024 following approval of the extension by Empire State Development. Please contact me with any questions.

Sincerely,

Eric Ennis
Deputy Commissioner

**Department of
Neighborhood &
Business Development**
201 E Washington Street
Suite 600
Syracuse, NY 13202

Cc:
Michael Collins, NBD Commissioner
Sharon Owens, Deputy Mayor

Office 315 448 8100
Fax 315 448 8036

www.syr.gov.net

GROWTH. DIVERSITY. OPPORTUNITY FOR ALL.

23



OFFICE OF MANAGEMENT & BUDGET

CITY OF SYRACUSE, MAYOR BEN WALSH

Timothy M. Rudd
Director

Julie Castellitto
Assistant Director

TO: Mayor Ben Walsh
FROM: Julie Castellitto, Assistant Director of Management and Budget *ac*
DATE: October 2, 2023
SUBJECT: Amend Ordinance #728-2022 – Upstate Minority Economic Alliance (UMEA)

On behalf of the Department of Neighborhood & Business Development, I am requesting to amend Ordinance #728-2022 in order to extend a contract agreement with the Upstate Minority Economic Alliance (UMEA) through March 31, 2024. UMEA is a sub-grantee in the amount of \$70,000 as part of the Business Growth Accelerator Program. NYS Empire State Development has awarded funds to the City of Syracuse to implement a Business Growth Accelerator (BGA) program in the Central New York and Mohawk Valley regions of the state. There is no change in the contract award amount.

The purpose of the BGA is to deliver a business development program for up to twenty (20) current NYS-certified MWBE firms.

The grant period will now extend through March 31, 2024 following approval of the extension by Empire State Development. Please contact me with any questions.

Please indicate your concurrence by signing below and returning this memo to me so that I may then forward your approval to the Common Council along with the request for authorizing this legislation.

Thank you for your attention regarding this matter.



Mayor Ben Walsh
City of Syracuse, New York

10/4/23
Date

Office of Management
and Budget
233 E Washington St
Room 213
Syracuse, N.Y. 13202

Office 315 448-8252
Fax 315 448-8116

www.syr.gov.net



DEPARTMENT OF NEIGHBORHOOD & BUSINESS DEVELOPMENT

CITY OF SYRACUSE, MAYOR BEN WALSH

37

September 29, 2023

Patricia McBride, City Clerk
Office of the City Clerk
Room 231, City Hall
Syracuse, NY 13202

Commissioner
Michael Collins

**Deputy Commissioner of
Neighborhood
Development**
Michelle Sczpanski

**Deputy Commissioner of
Business Development**
Eric Ennis

Re: Legislation Request – Amend Ordinance #729-2022 – Syracuse Business Growth Accelerator Program – OMNI Procurement Solutions, LLC.

Dear Ms. McBride,

Please prepare the legislation to amend Ordinance #729-2022 in order to extend a contract agreement with OMNI Procurement Solutions, LLC (OMNI) through March 31, 2024. OMNI is a sub-grantee in the amount of \$202,000 as part of the Business Growth Accelerator Program. NYS Empire State Development has awarded funds to the City of Syracuse to implement a Business Growth Accelerator (BGA) program in the Central New York and Mohawk Valley regions of the state. There is no change in the contract award amount.

The purpose of the BGA is to deliver a business development program for up to twenty (20) current NYS-certified MWBE firms.

The grant period will now extend through March 31, 2024 following approval of the extension by Empire State Development. Please contact me with any questions.

Sincerely,

Eric Ennis
Deputy Commissioner

**Department of
Neighborhood &
Business Development**
201 E Washington Street
Suite 600
Syracuse, NY 13202

Cc:
Michael Collins, NBD Commissioner
Sharon Owens, Deputy Mayor

Office 315 448 8100
Fax 315 448 8036

www.syr.gov.net

GROWTH. DIVERSITY. OPPORTUNITY FOR ALL.

22



OFFICE OF MANAGEMENT & BUDGET

CITY OF SYRACUSE, MAYOR BEN WALSH

Timothy M. Rudd
Director

Julie Castellitto
Assistant Director

TO: Mayor Ben Walsh
FROM: Julie Castellitto, Assistant Director of Management and Budget *al*
DATE: October 2, 2023
SUBJECT: Amend Ordinance #729-2022 – OMNI Procurement Solutions, LLC (OMNI)

On behalf of the Department of Neighborhood & Business Development, I am requesting to amend Ordinance #729-2022 in order to extend a contract agreement with OMNI Procurement Solutions, LLC (OMNI) through March 31, 2024. OMNI is a sub-grantee in the amount of \$202,000 as part of the Business Growth Accelerator Program. NYS Empire State Development has awarded funds to the City of Syracuse to implement a Business Growth Accelerator (BGA) program in the Central New York and Mohawk Valley regions of the state. There is no change in the contract award amount.

The purpose of the BGA is to deliver a business development program for up to twenty (20) current NYS-certified MWBE firms.

The grant period will now extend through March 31, 2024 following approval of the extension by Empire State Development. Please contact me with any questions.

Please indicate your concurrence by signing below and returning this memo to me so that I may then forward your approval to the Common Council along with the request for authorizing this legislation.

Thank you for your attention regarding this matter.

Mayor Ben Walsh
City of Syracuse, New York

10/4/23
Date

Office of Management
and Budget
233 E Washington St
Room 213
Syracuse, N.Y. 13202

Office 315 448-8252
Fax 315 448-8116

www.syr.gov



38

DEPARTMENT OF NEIGHBORHOOD & BUSINESS DEVELOPMENT

CITY OF SYRACUSE, MAYOR BEN WALSH

September 29, 2023

Commissioner
Michael Collins

Deputy Commissioner of Neighborhood Development
Michelle Sczpanski

Deputy Commissioner of Business Development
Eric Ennis

Patricia McBride, City Clerk
Office of the City Clerk
Room 231, City Hall
Syracuse, NY 13202

Re: Legislation Request – Amend Ordinance #368-2023; Authorize Use of Bonding for Purposes of the new City Office Space at 300 South State Street

Dear Ms. McBride,

Please prepare legislation for the October 16, 2023 meeting of the Syracuse Common Council amending Ordinance #368-2023 authorizing the City to add RightPrice Companies, Sedgewick Business Interiors, Grainger, and Baruch Park Place, LLC as authorized vendors in order to purchase furniture and other necessary materials for an amount not to exceed \$800,000. The use of funds is for the purchase of furniture and other materials necessary for the City to complete the relocation of staff to new office space located at 300 South State Street, known as One Park Place. Expenses will be charged to account number 07.64205.706420523.599807.

Please contact me if you have any questions.

Sincerely,

Eric Ennis
Deputy Commissioner

Department of Neighborhood & Business Development
201 E Washington Street
Suite 600
Syracuse, NY 13202

Office 315 448 8100
Fax 315 448 8036

www.syr.gov.net

Cc: Michael Collins, NBD Commissioner
Tim Rudd, Director of Budget
Frank Caliva, Chief Administrative Officer
Corey Driscoll Dunham, Chief Operating Officer
Matthew Oja, Commissioner of Assessment

21



OFFICE OF MANAGEMENT & BUDGET

CITY OF SYRACUSE, MAYOR BEN WALSH

Timothy M. Rudd
Director

Julie Castellitto
Assistant Director

TO: Mayor Ben Walsh
FROM: Julie Castellitto, Assistant Director of Management and Budget *ac*
DATE: October 2, 2023
SUBJECT: Amend Ordinance #368-2023 – RightPrice, Sedgewick Business Interiors, Grainger, and Baruch Park Place, LLC

On behalf of the Department of Neighborhood & Business Development, I am requesting to amend Ordinance #368-2023 authorizing the City to add RightPrice Companies, Sedgewick Business Interiors, Grainger, and Baruch Park Place, LLC as authorized vendors in order to purchase furniture and other necessary materials for an amount not to exceed \$800,000. The use of funds is for the purchase of furniture and other materials necessary for the City to complete the relocation of staff to new office space located at 300 South State Street, known as One Park Place. Expenses will be charged to account number 07.64205.706420523.599807.

Please indicate your concurrence by signing below and returning this memo to me so that I may then forward your approval to the Common Council along with the request for authorizing this legislation.

Thank you for your attention regarding this matter.



Mayor Ben Walsh
City of Syracuse, New York

10/4/23
Date

Office of Management
and Budget
233 E Washington St
Room 213
Syracuse, N.Y. 13202

Office 315 448-8252
Fax 315 448-8116

www.syr.gov.net

One Park Place Furniture Bonding Authorization	
Expense	Anticipated Total Amount
Phase I - CPO Space	
• 1 Office	\$ 39,434.00
• 1 Conference Room table + 8 Chairs	
• 11 Work Stations	
Phase I - 7th Floor	
• 33 Offices	\$ 582,303.00
• 3 Conference Room tables + 24 Chairs	
• 142 Work Stations	
Executive Conference Room + Break Room	
• 64 conference room chairs	\$ 25,000.00
• 22 conference room chairs	
• 8 break room tables	
• 21 break room chairs	
Phase II - 7th Floor	
• 8 Offices	\$ 153,263.00
• 20 work stations	
• 8 conference room tables + 18 chairs	
• 21 break room chairs	
TOTAL	\$ 800,000.00

Ordinance No.

2023

**ORDINANCE AUTHORIZING MAYOR TO
SUBMIT AN APPLICATION FOR A GRANT
FROM THE NEW YORK STATE DIVISION OF
HOMELAND SECURITY AND EMERGENCY
SERVICES FOR A 2021 BOMB SQUAD
INITIATIVE (BS21) GRANT AND EXECUTE A
CONTRACT OR WRITTEN INSTRUMENTS
ASSOCIATED WITH THE GRANT AS
NECESSARY**

BE IT ORDAINED, that the Mayor be and he hereby is authorized to submit an application to the New York State Division of Homeland Security and Emergency Services for a 2021 Bomb Squad Initiative Grant (BS21) in an amount not to exceed \$91,660.00; said funds will be used by the City of Syracuse Police Department for a combination of equipment purchases and training classes for the Bomb Squad; no local match is required; and

BE IT FURTHER ORDAINED, that upon receipt of said grant, the Mayor be and he hereby is authorized to execute a contract or written instruments as approved by the Corporation Counsel; and

BE IT FURTHER ORDAINED, that upon receipt of said funds or any part thereof, pursuant to said application authorized herein, the Commissioner of Finance is authorized and directed to deposit the same in an appropriate account to be determined by him.



Bureau of Research

CITY OF SYRACUSE, MAYOR BEN WALSH

Janet L. Burke
Director, Bureau of
Research

September 27, 2023

Ms. Patricia McBride
City Clerk
231 City Hall
Syracuse, New York 13202

Dear City Clerk McBride:

Please prepare legislation for the next meeting of the Common Council authorizing the City of Syracuse to apply for and enter into an agreement with the New York State Division of Homeland Security and Emergency Services for the 2021 Bomb Squad Initiative Grant (BS21). The application submissions will be regional with the City of Syracuse, the Village of Endicott and Onondaga County as regional recipients. The full regional allocation for BS21 is \$275,000.00. The police department intends to apply for a grant of \$91,666.00 for a combination of equipment purchases and training classes for the Bomb Squad Team.

The total contract amount is not to exceed \$91,666.00. No local match is required.

Sincerely,

Janet L. Burke
Director

Bureau of Research
233 E Washington St.
Room 419
Syracuse, N.Y. 13202

Office 315 448-8020
Fax 315 448-8008

www.syr.gov.net

Ordinance No.

2023

**ORDINANCE AUTHORIZING MAYOR TO
SUBMIT AN APPLICATION FOR A GRANT
FROM THE NEW YORK STATE DIVISION OF
HOMELAND SECURITY AND EMERGENCY
SERVICES FOR A 2022 BOMB SQUAD
INITIATIVE (BS21) GRANT AND EXECUTE A
CONTRACT OR WRITTEN INSTRUMENTS
ASSOCIATED WITH THE GRANT AS
NECESSARY**

BE IT ORDAINED, that the Mayor be and he hereby is authorized to submit an application to the New York State Division of Homeland Security and Emergency Services for a 2022 Bomb Squad Initiative Grant (BS22) in an amount not to exceed \$83,333.00; said funds will be used by the City of Syracuse Police Department for a combination of equipment purchases and training classes for the Bomb Squad; no local match is required; and

BE IT FURTHER ORDAINED, that upon receipt of said grant, the Mayor be and he hereby is authorized to execute a contract or written instruments as approved by the Corporation Counsel; and

BE IT FURTHER ORDAINED, that upon receipt of said funds or any part thereof, pursuant to said application authorized herein, the Commissioner of Finance is authorized and directed to deposit the same in an appropriate account to be determined by him.



Bureau of Research

CITY OF SYRACUSE, MAYOR BEN WALSH

Janet L. Burke
Director, Bureau of
Research

September 27, 2023

Ms. Patricia McBride
City Clerk
231 City Hall
Syracuse, New York 13202

Dear City Clerk McBride:

Please prepare legislation for the next meeting of the Common Council authorizing the City of Syracuse to apply for and enter into an agreement with the New York State Division of Homeland Security and Emergency Services for the 2022 Bomb Squad Initiative Grant (BS22). The application submissions will be regional with the City of Syracuse, the Village of Endicott and Onondaga County as regional recipients. The full allocation for BS22 is \$250,000.00. The police department intends to apply for a grant of \$83,333.00 for a combination of equipment purchases and training classes for the Bomb Squad Team.

The total contract amount is not to exceed \$83,333.00. No local match is required.

Sincerely,

Janet L. Burke
Director

Bureau of Research
233 E Washington St.
Room 419
Syracuse, N.Y. 13202

Office 315 448-8020
Fax 315 448-8008

www.syr.gov.net

Ordinance No.

2023

**ORDINANCE AUTHORIZING MAYOR TO
SUBMIT AN APPLICATION FOR A GRANT
FROM THE NEW YORK STATE DIVISION OF
HOMELAND SECURITY AND EMERGENCY
SERVICES FOR A 2021 TECHNICAL RESCUE &
URBAN SEARCH AND RESCUE (USAR21)
GRANT AND EXECUTE A CONTRACT OR
WRITTEN INSTRUMENTS ASSOCIATED WITH
THE GRANT AS NECESSARY**

BE IT ORDAINED, that the Mayor be and he hereby is authorized to submit an application to the New York State Division of Homeland Security and Emergency Services for a 2021 Technical Rescue & Urban Search and Rescue Grant (USAR21) in an amount not to exceed \$75,000.00; said funds will be used by the City of Syracuse Fire Department for overtime and backfill while Fire Department personnel attend Urban Search and Rescue (USAR) Technical Training; no local match is required; and

BE IT FURTHER ORDAINED, that upon receipt of said grant, the Mayor be and he hereby is authorized to execute a contract or written instruments as approved by the Corporation Counsel; and

BE IT FURTHER ORDAINED, that upon receipt of said funds or any part thereof, pursuant to said application authorized herein, the Commissioner of Finance is authorized and directed to deposit the same in an appropriate account to be determined by him.



Bureau of Research

CITY OF SYRACUSE, MAYOR BEN WALSH

Janet L. Burke
Director, Bureau of
Research

September 27, 2023

Ms. Patricia McBride
City Clerk
231 City Hall
Syracuse, New York 13202

Dear City Clerk McBride:

Please prepare legislation for the next meeting of the Common Council authorizing the City of Syracuse to apply for and enter into an agreement with the New York State Division of Homeland Security and Emergency Services for the 2021 Technical Rescue & Urban Search and Rescue Grant (USAR21).

The City's allocation for the USAR21 funds is \$75,000.00 to be used by the fire department for overtime and backfill while fire department personnel attend Urban Search and Rescue (USAR) Technical Rescue Training.

The total contract amount is not to exceed \$75,000.00. No local match is required.

Sincerely,

Janet L. Burke
Director

Bureau of Research
233 E Washington St.
Room 419
Syracuse, N.Y. 13202

Office 315 448-8020
Fax 315 448-8008

www.syr.gov.net

Ordinance No.

2023

**ORDINANCE AUTHORIZING MAYOR TO
SUBMIT AN APPLICATION FOR A GRANT
FROM THE NEW YORK STATE DIVISION OF
HOMELAND SECURITY AND EMERGENCY
SERVICES FOR A 2021 CRITICAL
INFRASTRUCTURE (CI21) GRANT AND
EXECUTE A CONTRACT OR WRITTEN
INSTRUMENTS ASSOCIATED WITH THE
GRANT AS NECESSARY**

BE IT ORDAINED, that the Mayor be and he hereby is authorized to submit an application to the New York State Division of Homeland Security and Emergency Services for a 2021 Critical Infrastructure Grant (CI21) in an amount not to exceed \$50,000.00; said funds will be used by the City of Syracuse Police Department to purchase equipment to enhance the protection of the Clinton Square area from vehicle borne attacks and by the City of Syracuse Fire Department to purchase equipment to support existing critical infrastructure assets; no local match is required; and

BE IT FURTHER ORDAINED, that upon receipt of said grant, the Mayor be and he hereby is authorized to execute a contract or written instruments as approved by the Corporation Counsel; and

BE IT FURTHER ORDAINED, that upon receipt of said funds or any part thereof, pursuant to said application authorized herein, the Commissioner of Finance is authorized and directed to deposit the same in an appropriate account to be determined by him.



42

Bureau of Research

CITY OF SYRACUSE, MAYOR BEN WALSH

Janet L. Burke
Director, Bureau of
Research

September 27, 2023

Ms. Patricia McBride
City Clerk
231 City Hall
Syracuse, New York 13202

Dear City Clerk McBride:

Please prepare legislation for the next meeting of the Common Council authorizing the City of Syracuse to apply for and enter into an agreement with the New York State Division of Homeland Security and Emergency Services for the 2021 Critical Infrastructure Grant (CI21).

The City's allocation for the CI21 funds is \$50,000.00 to be used by the fire and police departments for the following:

SPD – Equipment purchases to enhance the Clinton Square area from vehicle borne attacks.

SFD – Equipment purchases to supplement existing critical infrastructure assets.

The total contract amount is not to exceed \$50,000.00. No local match is required.

Sincerely,

Janet L. Burke
Director

Bureau of Research
233 E Washington St.
Room 419
Syracuse, N.Y. 13202

Office 315 448-8020
Fax 315 448-8008

www.syr.gov.net

27

Ordinance No.

2023

**ORDINANCE AUTHORIZING MAYOR TO
SUBMIT AN APPLICATION FOR A GRANT
FROM THE NEW YORK STATE DIVISION OF
HOMELAND SECURITY AND EMERGENCY
SERVICES FOR A 2021 TACTICAL TEAM
TARGETED (TT21) GRANT AND EXECUTE A
CONTRACT OR WRITTEN INSTRUMENTS
ASSOCIATED WITH THE GRANT AS
NECESSARY**

BE IT ORDAINED, that the Mayor be and he hereby is authorized to submit an application to the New York State Division of Homeland Security and Emergency Services for a 2021 Tactical Team Targeted Grant (TT21) in an amount not to exceed \$75,000.00; said funds will be used by the City of Syracuse Police Department to purchase equipment for the SWAT Team; no local match is required; and

BE IT FURTHER ORDAINED, that upon receipt of said grant, the Mayor be and he hereby is authorized to execute a contract or written instruments as approved by the Corporation Counsel; and

BE IT FURTHER ORDAINED, that upon receipt of said funds or any part thereof, pursuant to said application authorized herein, the Commissioner of Finance is authorized and directed to deposit the same in an appropriate account to be determined by him.



Bureau of Research

CITY OF SYRACUSE, MAYOR BEN WALSH

Janet L. Burke
Director, Bureau of
Research

September 27, 2023

Ms. Patricia McBride
City Clerk
231 City Hall
Syracuse, New York 13202

Dear City Clerk McBride:

Please prepare legislation for the next meeting of the Common Council authorizing the City of Syracuse to apply for and enter into an agreement with the New York State Division of Homeland Security and Emergency Services for the 2021 Tactical Team Targeted Grant (TT21).

The City's allocation for the TT21 funds is \$75,000.00 to be used by the police department for equipment purchases for the SWAT Team.

The total contract amount is not to exceed \$75,000.00. No local match is required.

Sincerely,

Janet L. Burke
Director

Bureau of Research
233 E Washington St.
Room 419
Syracuse, N.Y. 13202

Office 315 448-8020
Fax 315 448-8008

www.syr.gov.net

Ordinance No.

2023

**ORDINANCE AUTHORIZING MAYOR TO
SUBMIT AN APPLICATION FOR A GRANT
FROM THE NEW YORK STATE DIVISION OF
HOMELAND SECURITY AND EMERGENCY
SERVICES FOR A 2021 CYBERSECURITY (CS21)
GRANT AND EXECUTE A CONTRACT OR
WRITTEN INSTRUMENTS ASSOCIATED WITH
THE GRANT AS NECESSARY**

BE IT ORDAINED, that the Mayor be and he hereby is authorized to submit an application to the New York State Division of Homeland Security and Emergency Services for a 2021 Cybersecurity Grant (CS21) in an amount not to exceed \$50,000.00; said funds will be used by the City of Syracuse Police Department for security awareness training and to purchase three (3) backup servers; no local match is required; and

BE IT FURTHER ORDAINED, that upon receipt of said grant, the Mayor be and he hereby is authorized to execute a contract or written instruments as approved by the Corporation Counsel; and

BE IT FURTHER ORDAINED, that upon receipt of said funds or any part thereof, pursuant to said application authorized herein, the Commissioner of Finance is authorized and directed to deposit the same in an appropriate account to be determined by him.



44

Bureau of Research

CITY OF SYRACUSE, MAYOR BEN WALSH

Janet L. Burke
Director, Bureau of
Research

September 29, 2023

Ms. Patricia McBride
City Clerk
231 City Hall
Syracuse, New York 13202

Dear City Clerk McBride:

Please prepare legislation for the next meeting of the Common Council authorizing the City of Syracuse to apply for and enter into an agreement with the New York State Division of Homeland Security and Emergency Services for the 2021 Cybersecurity Grant (CY21).

The City's allocation for the CY21 funds is \$50,000.00 to be used by the police department for Security Training Awareness for all users and purchasing Three (3) back up servers.

The total contract amount is not to exceed \$50,000.00. No local match is required.

Sincerely,

Janet L. Burke
Director

Bureau of Research
233 E Washington St.
Room 419
Syracuse, N.Y. 13202

Office 315 448-8020
Fax 315 448-8008

www.syr.gov.net

29

Ordinance No.

2023

**ORDINANCE APPROVING THE REQUEST FOR
A TEMPORARY HONORARY STREET SIGN
LOCATED ON THE 100 BLOCK OF WALTON
STREET IN HONOR OF MICHAEL YORTON**

WHEREAS, Michael Yorton operated the Blue Tusk in Center Armory with his father, Tim, and other family members from 1992 until 2022; and

WHEREAS, Michael Yorton was the visionary behind the idea of a 69 tap bar featuring a wide variety of craft beer and hard to find beer; and

WHEREAS, the founding of the Blue Tusk with this new concept helped pave the way for craft beer to take off in Central New York; and

WHEREAS, the Blue Tusk won many accolades over the years including being ranked by the national magazine All About Beer as No. 48 on its list of the "Top 125 places in the world to have a beer before you die" putting the Blue Tusk ahead of bars in such places as London, Dublin, Munich and New York City; and

WHEREAS, in 2022, Michael Yorton tragically passed away at the age of 49 but left behind a great legacy of having created a very popular business for the people of Central New York.

NOW THEREFORE,

BE IT ORDAINED, subject to the approval of the Mayor, the Common Council authorizes that a temporary, one (1) year from the date of installation, Honorary Street Sign be installed on the 100 block of Walton Street in honor of Michal Yorton; and

BE IT FURTHER ORDAINED, that the Commissioner of DPW is authorized to install the appropriate honorary signage for a one (1) year period along the 100 block of Walton Street in the City of Syracuse.

4550



CITY OF SYRACUSE COMMON COUNCIL

LATOYA ALLEN
Councilor – 4th District

September 22, 2023

Ms. Patricia K. McBride
City Clerk
321 City Hall
Syracuse, New York 13202

Dear Ms. McBride:

Please prepare legislation for the Common Council meeting of Monday, October 2, 2023, requesting the temporary construction of an honorary street sign for one year from the date of installation on the 100 block of Walton Street in honor of Mr. Michael Yorton.

Yorton operated the Blue Tusk in Center Armory with his father, Tim, and other family members from 1992 until 2022. Yorton was the visionary behind the idea of a 69 tap bar featuring a wide variety of craft and hard to find beer. While its concept seemed unusual at its opening, the Blue Tusk helped pave the way for craft beer to take off in Central New York.

The Blue Tusk won many accolades over the years. In 2008, national magazine All About Beer ranked The Blue Tusk No. 48 in its list of "Top 125 places in the world to have a beer before you die." That puts it ahead of bars in such places as London, Dublin, Munich and New York City.

In 2022, Yorton tragically passed away at the age of 49. Through his business, Yorton created his own community and made many people's lives more enjoyable. Yorton's unique vision made him a legendary figure in the City of Syracuse.

Thank you for your assistance in this regard.

Sincerely,

Latoya Allen
4th District Councilor

41

Michael Yorton operated The Blue Tusk in the Center Armory building with his father, Tim, and other members of his family from 1995 to 2022.

Michael was the visionary behind the idea of a 69-tap bar highlighting both American craft beer and hard-to-find imports. He was responsible for the bar's laid-back, tie-dyed, jam band-meets-beer enthusiast vibe.

It may have seemed unusual at the time, but The Blue Tusk helped pave the way for the then-new concept of craft beer to take off in Central New York. It was recognized in national beer publications as a trend-setter. The Blue Tusk won many accolades over the years. In 2008, the writers and editors of the national magazine All About Beer ranked The Blue Tusk No. 48 in its list of "top 125 places in the world to have a beer before you die." That put it ahead of bars in such places as London, Dublin, Munich and New York City.

Michael saw that The Blue Tusk was among the first bars in Central New York to carry the beers that were then known as "micro" brews, several years before the term "craft" came into common use. He also carried a large selection of imports, among them a wide array of Belgian beers.

The Tusk was known to have helped the early small brewers in Syracuse and elsewhere find an outlet for their beer.

DRAFT

Ordinance No.

2023

ORDINANCE GRANTING PERMISSION TO ACROPOLIS CENTER LLC OWNER OF PROPERTY SITUATED AT 333 SOUTH SALINA STREET & EAST JEFFERSON STREET, SYRACUSE NEW YORK TO ENCROACH UP TO 2'6" INTO THE BANK ALLEY RIGHT-OF-WAY WITH FOUR (4) CONCRETE BOLLARDS AND ENCROACH UP TO 5' INTO THE BANK ALLEY RIGHT-OF-WAY WITH A CANOPY

WHEREAS, Acropolis Center LLC, owner of the property situated at 333 South Salina Street, Syracuse, New York, has requested permission to encroach up to 2'6" into the Bank Alley Right-of-Way with four (4) concrete Bollards and to encroach up to 5' into the Bank Alley Right-of-Way with a canopy; and

WHEREAS, the report of the Commissioner of the Department of Public Works is on file in the office of the City Clerk; NOW, THEREFORE,

BE IT ORDAINED, that this Common Council hereby grants permission to Acropolis Center LLC (hereinafter referred to as the "Owner") to maintain the aforementioned encroachment, subject to the following conditions:

1. The Owner shall defend, indemnify and save harmless the City of Syracuse, its officers and servants, from any and all liability and from any and all claims, damages, costs and expenses to person or property which may occur out of the usage of said street right-of-way heretofore described.

2. The Common Council may terminate this permission upon thirty (30) days notice to the Owner.

3. Said Owner, within thirty (30) days from the effective date of this ordinance, shall file in the office of the City Clerk a duly acknowledged written acceptance of this permission and consent to its terms and conditions. Said acceptance, when so filed, shall constitute an agreement on the part of the Owner to do and conform to all conditions thereof.

4. Said Owner shall obtain the necessary permits, in addition to this permission ordinance, for the four (4) bollards and the canopy.

5. Said Owner agrees and consents that the City will not be liable for any damage to the four (4) bollards or the canopy from any cause, including but not limited to snow removal, utility repair and replacement, and sidewalk repairs.

6. Said Owner agrees and consents to maintain compliance with the requirements of the various City Departments attached hereto as Appendix "A".

Appenix "A"



Department of Neighborhood & Business Development
Central Permit Office
 Ben Walsh, Mayor

Encroach (Minor) Plan Review Comments for Applicant
 (Revised 07/15)

Location of Proposed Work: 333 Salina St S & Jefferson St E

Permit #: PC-0238-23

Permit Type: Encroach (Minor)

Date: 09/21/2023

Contact: Acropolis Center, LLC

Phone #: 315-391-9654

The departments below have reviewed your application and provided the following comments.
Approval is subject to the conditions listed below.

Approval	Status Date	Status	Reviewer	Comments
DPW - Commissioner	06/08/2023	Conditionally Approved	Martin Davis	Leave 3' clear for snow shelf Do not block public sidewalk
DPW - Sanitation & Sewers	05/15/2023	Conditionally Approved	Vinny Esposito	all utilities in the area must be located and protected.
DPW - Sidewalk Inspector	06/05/2023	Approved	Chris Ettinger	Can not block pedestrian travel.
DPW - Traffic Control	05/18/2023	Conditionally Approved	Joe DiBello	no issue
DPW - Transportation Planner	05/16/2023	Internal Review Complete	Neil Milcarek-Burke	Bollard detail must show k-rated items and/or NYSDOT Sec. 10.2.2.8 approved items. Bollard must be sleeved with retroreflective and high-visibility materials per MUTCD, NYSDOT, and any other pertinent guidance.
Engineering - Design & Construction	05/26/2023	Conditionally Approved	John Kivlehan	Plans do not detail the sidewalk width, bollards shall be located as to not interfere with the pedestrian circulation path as established on the sidewalk along Bank Alley, bollards shall be located as close as practical to the building, if bollards encroach into the walkway and fail to provide the required ADA cleared walkway construction shall not progress; if after construction the City discovers ADA clearance is not being met then the bollards shall be removed. Ok for canopy encroachment, canopy to be set to provide required vertical clearance over sidewalk, applicant responsible to determine structural integrity of their building for canopy anchoring system.
Engineering - Mapping	05/18/2023	Not Applicable	Ray Wills	No impact on Mapping Division assets in the area. Deferring to Design and Construction, DPW and the City Engineer for traffic impact and approval determination.
Engineering - Sewers	05/26/2023	Conditionally Approved	John Kivlehan	Locate and protect sewers, maintain required separation from sewers and associated structures as applicable
Zoning Planner	06/05/2023	Approved	Lisa Welch	-
Engineering - City Engineer	06/15/2023	Conditionally Approved	Mary Robison	- Place bollards as close to building as possible to allow for snow storage area and minimum 5' sidewalk width. A minimum 5' sidewalk width shall be maintained. - UFPO prior to construction of bollards and maintain proper separation from all utilities. - Bollards shall be reflectorized as detailed in DPW Transportation comments. - No concerns with canopy except that it shall be installed at a proper height to allow for future construction repairs/ improvements in the City ROW. - The applicant shall indemnify the City & assume all liability for any damages or injuries caused to, from or as a result of this encroachment, its installation & maintenance.

Department of Public Works

ENCROACHMENT PERMIT ROUTING FORM

ADDRESS: 333 Salina St (Behind in Bank Alley)

APPLICATION DATE: 5-12-23

PROPERTY: 101.-06-02.3

PERMIT APPLICATION: PC-0238-23

OWNER: Acropolis Center LLC

MINOR OR MAJOR ENCROACHMENT

CONTRACTOR:

PHONE: 315-391-9654

EMAIL: ryan.c.benz@gmail.com

DESCRIPTION OF WORK: Seeking Encroachment for Bollards and Canopy in Bank Alley

To:

ASSESSMENT

DPW

ENGINEERING

FIRE PREVENTION LAW

NBD

PLANNING

POLICE

WATER

ZONING

DISTRICT COUNSILOR

CENTRO

NATIONAL GRID

VERIZON

APPROVED/DENIED _____

REVIEWED BY _____

DATE _____

COMMENTS _____

This form is for the reviewing departments use only. Please do not return the Central Permit Office.

The applicant will receive the review comments that have been entered in IPS.

If you have any questions please call 315-448-47-15 or email centralpermitoffice@syrgov.net.

Thank you

Encroachment Permit Instructions and Application

Jeremy Robinson
Commissioner



Ann Fordock
Deputy Commissioner

Martin E. Davis, L.S.
Deputy Commissioner

DEPARTMENT OF PUBLIC WORKS

Ben Walsh, Mayor

Encroachment Application and documents must be submitted to:

Central Permit Office
201 East Washington Street, Room 101
Syracuse, New York 13202, Phone # 315-448-4715
CentralPermitOffice@syrgov.net

SUBMITTAL REQUIREMENTS

Only complete applications will be accepted for review:

- Pages 5 and 6 of the Encroachment Application completed in full and signed by the owner of the property adjacent to the right-of-way.
- A copy of the stamped survey map* (**must be to scale, not reduced**) for the private property abutting the street right-of-way in question.
- A stamped or signed site plan* (**must be to scale, not reduced**) showing specific location and distances from front of main building abutting right-of-way, front and side property lines, curbs, sidewalks, sidewalk widths, and driveways and improvement dimensions (lengths, widths, and heights) for all encroaching features. Also, for fencing, location of any gates and direction they will open. **The proposal can be drawn (to scale) on a copy of the property survey, but applicant must initial all changes made to the stamped survey and cross out the surveyor's stamp.**
- Elevation drawing* or manufacturer's catalogue cut of any features of the improvement.

**If you submit full size architectural drawings or survey maps, you must also submit one additional copy no larger than 11" x 17" or an electronic copy.*

PLEASE FILL IN COMPLETELY

Address of Proposed Encroachment:

BEHIND (IN BANK ALLEY)
333 S. SALINA ST., SYRACUSE, NY 13202
Street address abutting the right-of-way where the improvement is being requested

Section, Block & Lot # (if known)

101.-06-02.3

Property Owner (print name):

ACROPOLIS CENTER, LLC

Mailing Address (if different):

115 E. JEFFERSON ST. STE 300, SYRACUSE, NY 13202

Phone #(s):

315.391.9654

Email Address(es):

RYAN.C.BENZ@gmail.com

PC-0238-23

Encroachment Permit Instructions and Application

Applicant / Owner's Representative (print name):

RYAN BENZ

Mailing Address:

SAME

Phone #(s):

SAME

Email Address:

SAME

Type of improvement requested:

INSTALLATION OF BOLLARDS - CONCRETE 12" ROUND

BY 36" TALL, PLUS ANCHORS INTO GROUND

Describe the style &/or materials of the improvement:

FOUR (4) CONCRETE BOLLARDS 12" X 36"

Ex: a picket fence; a masonry bench

List the dimensions of the improvement in feet and inches:

Horizontal: 12" Round Vertical: 36" TALL

What is the reason(s) for the improvement?

PER DPW, AIRBORNE CENTER, LLC, AS APPLICANT REQUIRES THE INSTALLATION OF BOLLARDS TO PROTECT AGAINST ERRANT VEHICLE PARKING THAT COULD OBSTRUCT EGRESS Specify any hardship or special circumstances, or public benefit to be gained, if applicable. Attach documentation or a letter of explanation if necessary.

Is this improvement part of a larger project?

Yes No

BUILDING OF A ROOFTOP RESTAURANT + BAR. ALSO APPLIED FOR CITY BODG. PERMITS.

If yes, please identify the project and specify the additional city/county approvals being applied for

How far does the feature encroach into the City's Right of Way?

BOLLARDS WILL BE 2' 6" FROM BODG. (12" ROUND CANOPY WILL PROTRUDE 5' FROM BODG. AND BE 10' LONG. ON CENTER)

SIGNATURE OF THE OWNER

I (we) certify that I (we) own the private property listed above (i.e., the property abutting the requested improvement).

Signature(s):

[Signature]

3-28-23

Date

Date



Model # TF6020 | 12" Diameter Cylinder Concrete Bollard

Print | Close Window

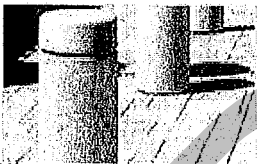
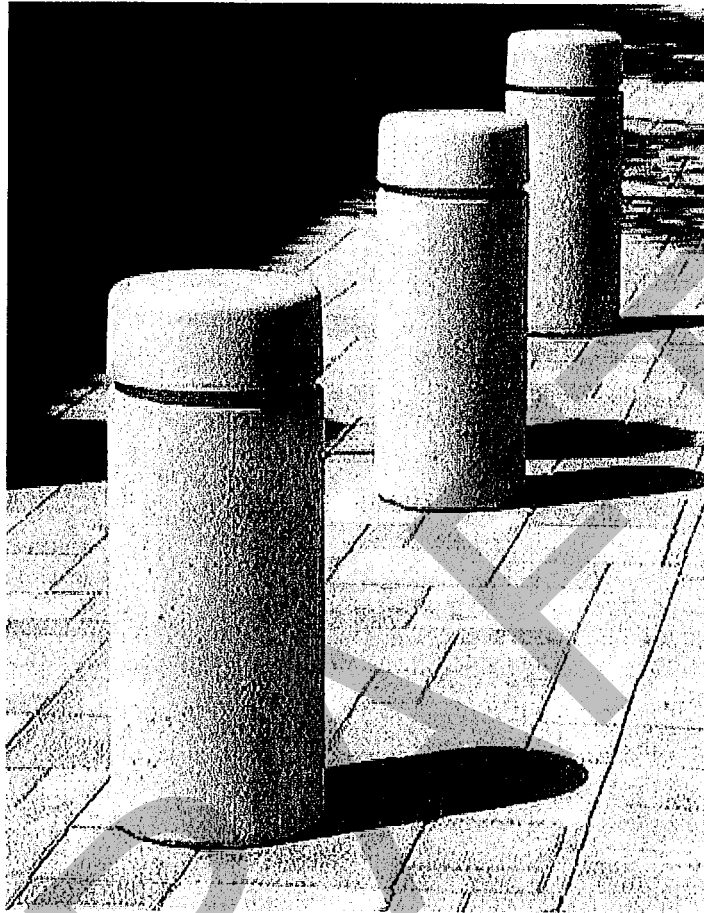

Model #TF6020

Dimension Sheet

12" Diameter Cylinder Concrete Bollard

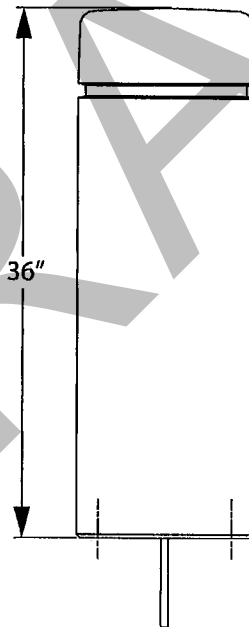
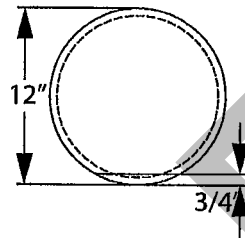



Your Outdoor Superstore

Concrete Bollard Anchor Style B | Barricade

Print | Close Window

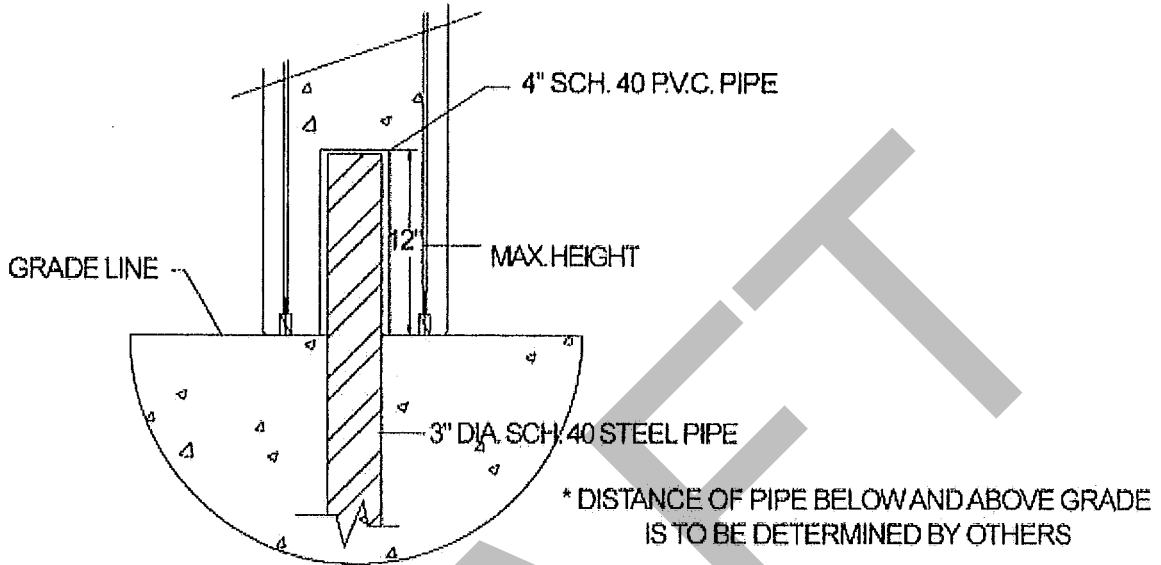

NOTE: THIS TYPE ANCHORING IS ALSO USED AS A BARRICADE, BOLLARD HELD IN PLACE BY STEEL PIPE STEEL PIPE MUST BE ANCHORED IN CONCRETE FOOTING

TYP. 12" DIA. CONCRETE BOLLARD SAME ANCHORING SYSTEM USED ON 14" AND 18" DIA. OR SQ. BOLLARDS

627 Amersale Drive | Naperville, IL 60563 | (800) 323-5664 | Fax: (630) 897-0573 | sales@belson.com

Copyright © 1993-2023, Belson Outdoors, LLC

Up Against a Deadline? Ask About QuickShip Options - Popular Products, Right Away!



Your Outdoor Superstore

1-800-323-5664

M-F 8:00am - 4:30pm CT

Home | About Us | Contact Us | FAQs | Site Map | Payments



QuickShip Popular Products, Right Away!

Click Here to Enable Options

Concrete Bollards



Precast Concrete Bollards

Use these precast concrete bollards to line your corporate drive, control traffic flow or heighten security around walkways. These column style bollards are aesthetically pleasing, fully functional and durable in harsh weather conditions. Available in the color options shown below in either the Weatherstone Concrete and Exposed Aggregate finish.

Please Note

There are two styles of anchoring available.

- Anchor Style A - for decorative installation.
- Anchor Style B - for barricade installation.



QuickShip Enable Options

- ▶ Need a Concrete Waste Container Fast?
- ▶ Click Here to Show Models, Colors and Options that are QuickShip Ready.

Dimensions: 12" Dia. x 36" H

Weatherstone Color Options



Acid Wash Color Options

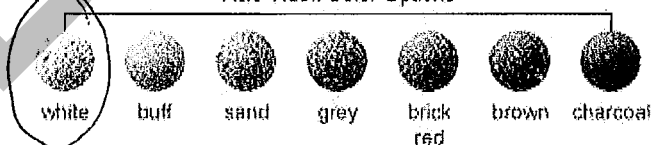

Exposed Aggregate Color Options

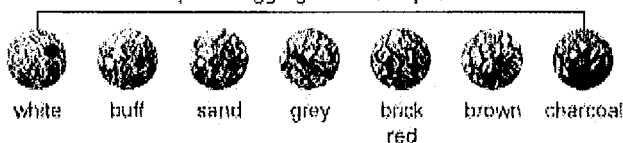

▼ Item Specific Details Available on Linked Model Numbers Below



Pages

ARCHITECTURAL CANOPIES
UNRIVALED.

LUMISHADE

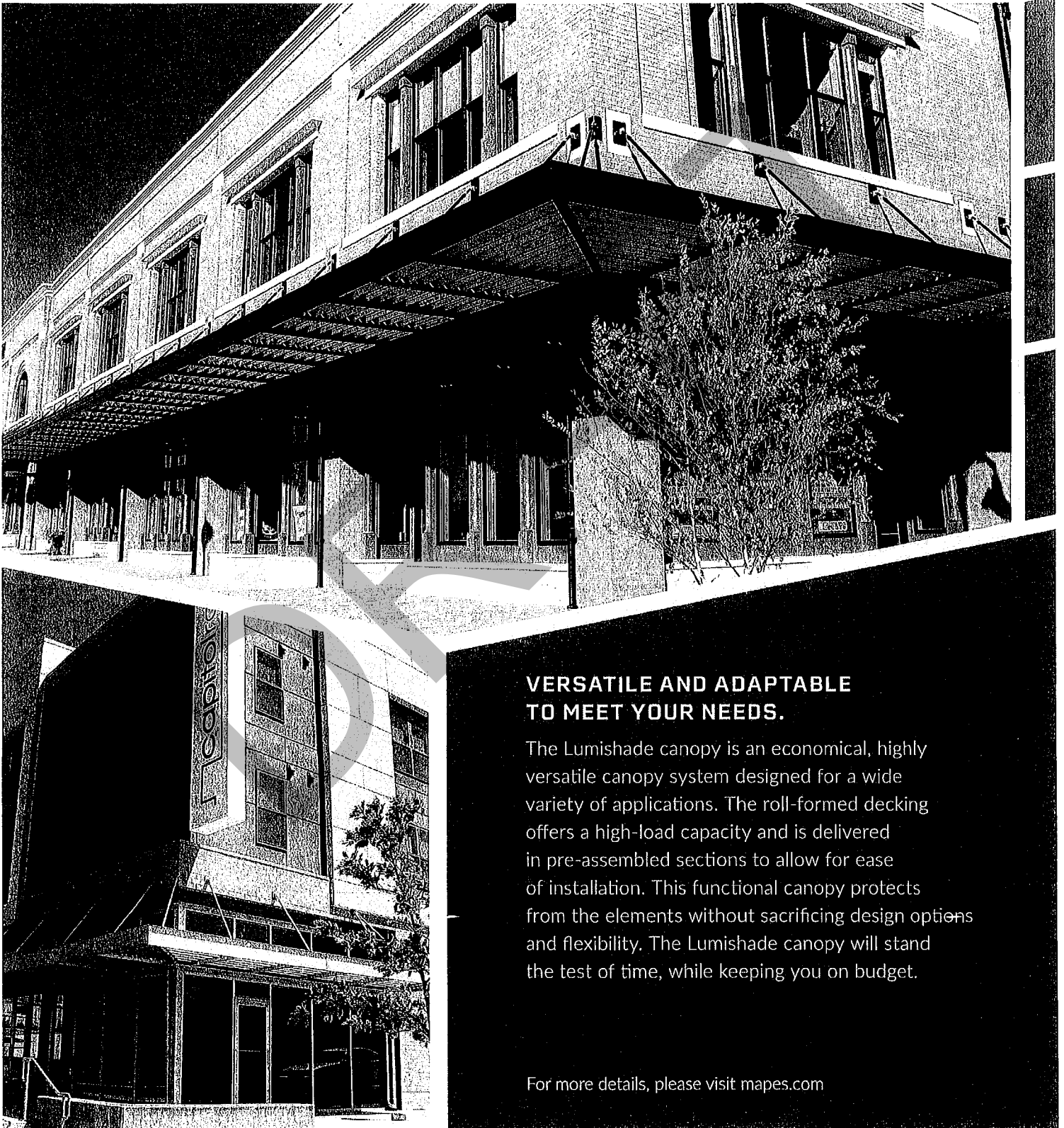

**VERSATILE AND ADAPTABLE
TO MEET YOUR NEEDS.**

The Lumishade canopy is an economical, highly versatile canopy system designed for a wide variety of applications. The roll-formed decking offers a high-load capacity and is delivered in pre-assembled sections to allow for ease of installation. This functional canopy protects from the elements without sacrificing design options and flexibility. The Lumishade canopy will stand the test of time, while keeping you on budget.

For more details, please visit mapes.com

LUMISHADE TECHNICAL DATA

All Aluminum (T6 - 6063)

Fascia .125"

Decking .040" Roll-formed

Deflection rating L/180

Maximum Projection

10' w/ hanger rod supports

5' w/ cantilever supports

Note: Engineered stamped calcs available in all 50 states

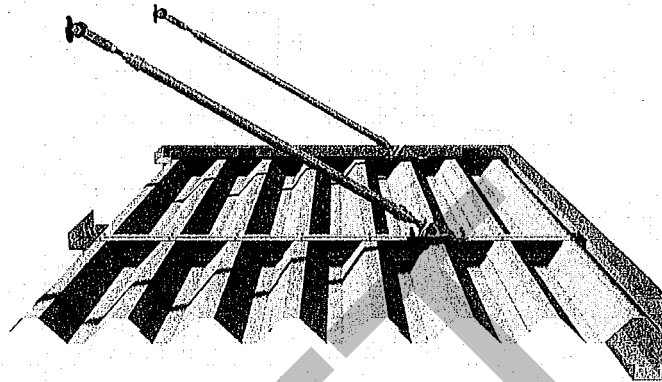

CANOPY DETAILS

	Finishes	Warranty	Specifications	Application
Mapes Standard Finishes	Clear Anodized, White Baked Enamel, & Bronze Baked Enamel	1 year	Meets AAMA 2603 specifications	Factory applied
2-Coat Kynar*	25 stock colors w/ unlimited custom matching options	10 years	70% Fluoropolymer meets AAMA 2605 specifications	Professionally applied & cured by certified finisher

Additional lead times and costs associated w/ premium paints & custom color matching

FEATURES

- .040 Roll-formed decking
- Economical
- High-load capacity
- Modular design
- Rust & maintenance free
- Custom details & colors
- Pre-assembled sections

APPLICATIONS

- Door & window covers
- Loading docks
- Parking garages
- Storefronts
- Passive solar
- Shopping centers

DECK OPTIONS



FASCIA OPTIONS

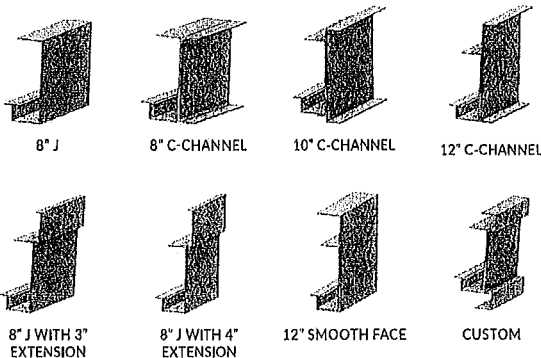

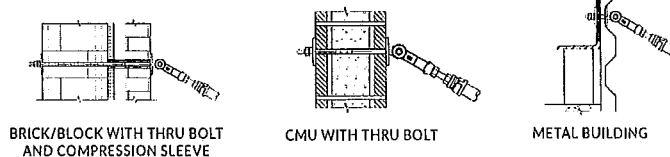

WALL MOUNT DETAILS



MAPES ARCHITECTURAL CANOPIES

7748 North 56th Street, Lincoln, NE 68514 Phone: 888-273-1132 Fax: 877-455-6572 mapes.com

 **[888] 273-1132**
<https://mapescanopies.com/color-charts/>

 [\(https://mapescanopies.com\)](https://mapescanopies.com/)
 [\(https://mapescanopies.com/quote-request/\)](https://mapescanopies.com/quote-request/)

 [\(https://mapescanopies.com/spec-builder\)](https://mapescanopies.com/spec-builder/)

COLOR CHARTS

Command attention to the entrance of your structure with a variety of standard and premium Kynar colors available for your architectural canopy. Mapes aluminum non-rusting finish has a much longer life span as compared to the typical field painted finishes used on typical structural steel canopies. Due to the differences between monitors and various computer platforms, the colors shown here are only an approximation of the actual color available.

Due to the differences between monitors and various computer platforms, the colors shown here are only an approximation of the actual color available.

Give the colors a try with our [Color Preview Tool \(http://mapescanopies.com/color-preview-tool/\)](http://mapescanopies.com/color-preview-tool/).

MAPES STANDARD FINISHES

Standard finishes come with a 1 year finish warranty and meet AAMA 2603 specification.

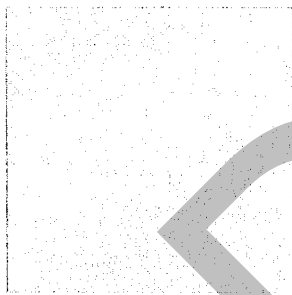

CLEAR ANODIZED *

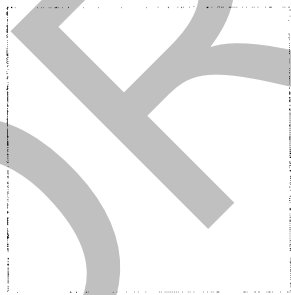

MAPES WHITE BAKED ENAMEL

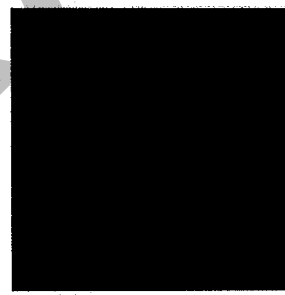

MAPES BRONZE BAKED ENAMEL

** Color is not representative of Clear Anodized. Please consult factory for actual sample.*

MAPES TWO COAT KYNAR COLORS

Premium Charges Apply

Kynar finishes come with a 10 year warranty and meet AAMA 2605 specifications.

M### - LUMISHADE HANGER ROD CANOPY / FRONT DRAINAGE
 MAPES CANOPIES / LINCOLN, NE

Canopy Type:

Architect:

Drawn: 12/3/2019 BJW

Mapes
 Architectural
 Canopies

7748 N. 56th St.
 Lincoln, NE 68514-9724
 Ph: (888) 273-1132
 Fx: (877) 455-6572
 email: cad@mapes.com

Prepared for:
 MAPES CANOPIES ()
 LINCOLN, NE

Job Name:
 LUMISHADE HANGER ROD
 CANOPY / FRONT DRAINAGE

Pc # / old
 M###

Ref:

sheet:

M###

01

Dec. 3, 19

of 10

Canopy Type

Architect

Drawn: 12/3/2019 BJW

Mapes Architectural Canopies

7748 N. 56th St.
Lincoln, NE. 68514-9724
Ph: (866) 273-1132
F: (877) 455-6572
email: cad@mapes.com

Prepared for:
MAPES CANOPIES ()
LINCOLN, NE

Job Name:
LUMSHADE HANGER ROD
CANOPY / FRONT DRAINAGE

PO / dtd
MG #

Rep:

M### sheet: 04
Dec. 3, 19
3/4" = 1'-0"

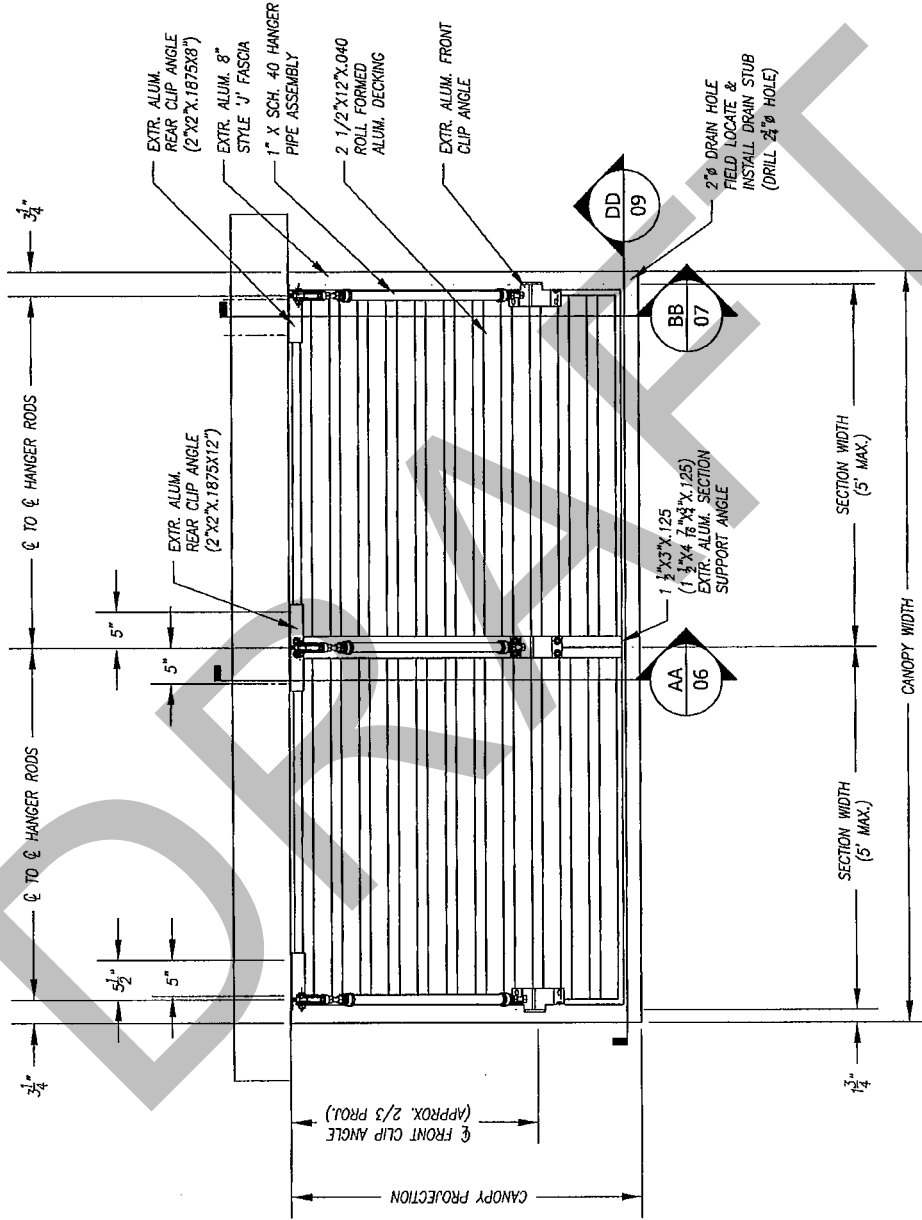

B CANOPY PLAN

Scale: 3/4" = 1'-0"

Canopy Type	
Architect	
Drawn:	12/3/2019 B/JW

Mapes Architectural Canopies
 7748 N. 56th St.
 Lincoln, NE. 68514-9724
 Ph: (866) 273-1132
 Fx: (877) 455-6572
 email: cat@mapes.com

Prepared for:
MAPES CANOPIES ()
 LINCOLN, NE

Job Name:
LUMISHADE HANGER ROD CANOPY / FRONT DRAINAGE

Rev # dtd Rep:
 M### sheet: **06**
 Dec. 3, 19 of 10
 1 1/2" = 1'-0"

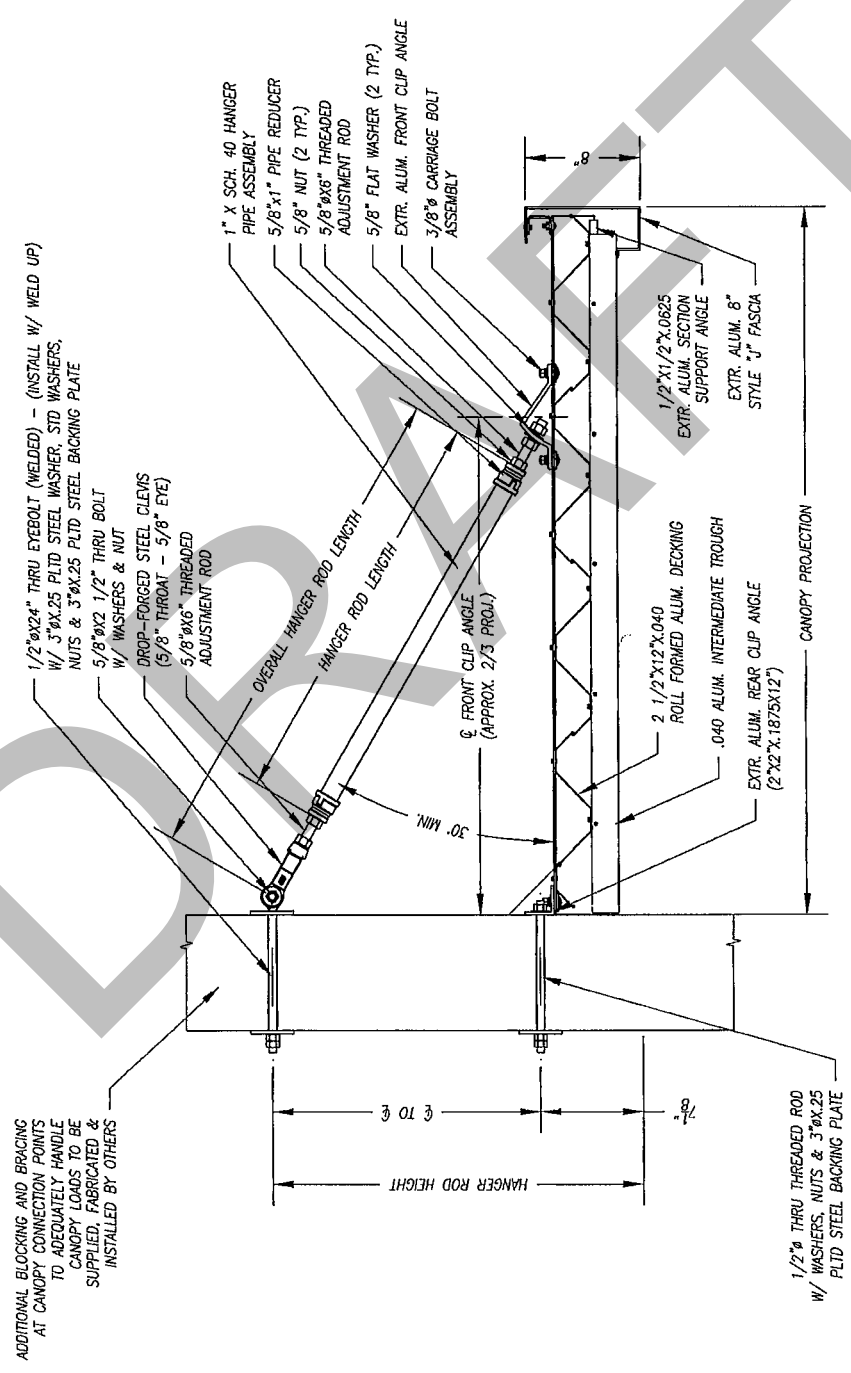

AA SECTION @ HANGER ROD
 Scale: 1 1/2" = 1'-0"

Canopy Type	
Architect	
Drawn	12/3/2019 BJW

Mapes Architectural Canopies
 7748 N. 56th St.
 Lincoln, NE. 68514-9724
 Ph: (800) 279-1132
 Fr: (877) 455-6572
 email: cad@mapes.com

Prepared for:
MAPES CANOPIES ()
 LINCOLN, NE

Job Name:
LONSHADE HANGER ROD CANOPY / FRONT DRAINAGE

PO / dtd
 M /

Rep:
 M### sheet: **07**
 Dec. 3, 19
 1 1/2" = 1'-0" of 10

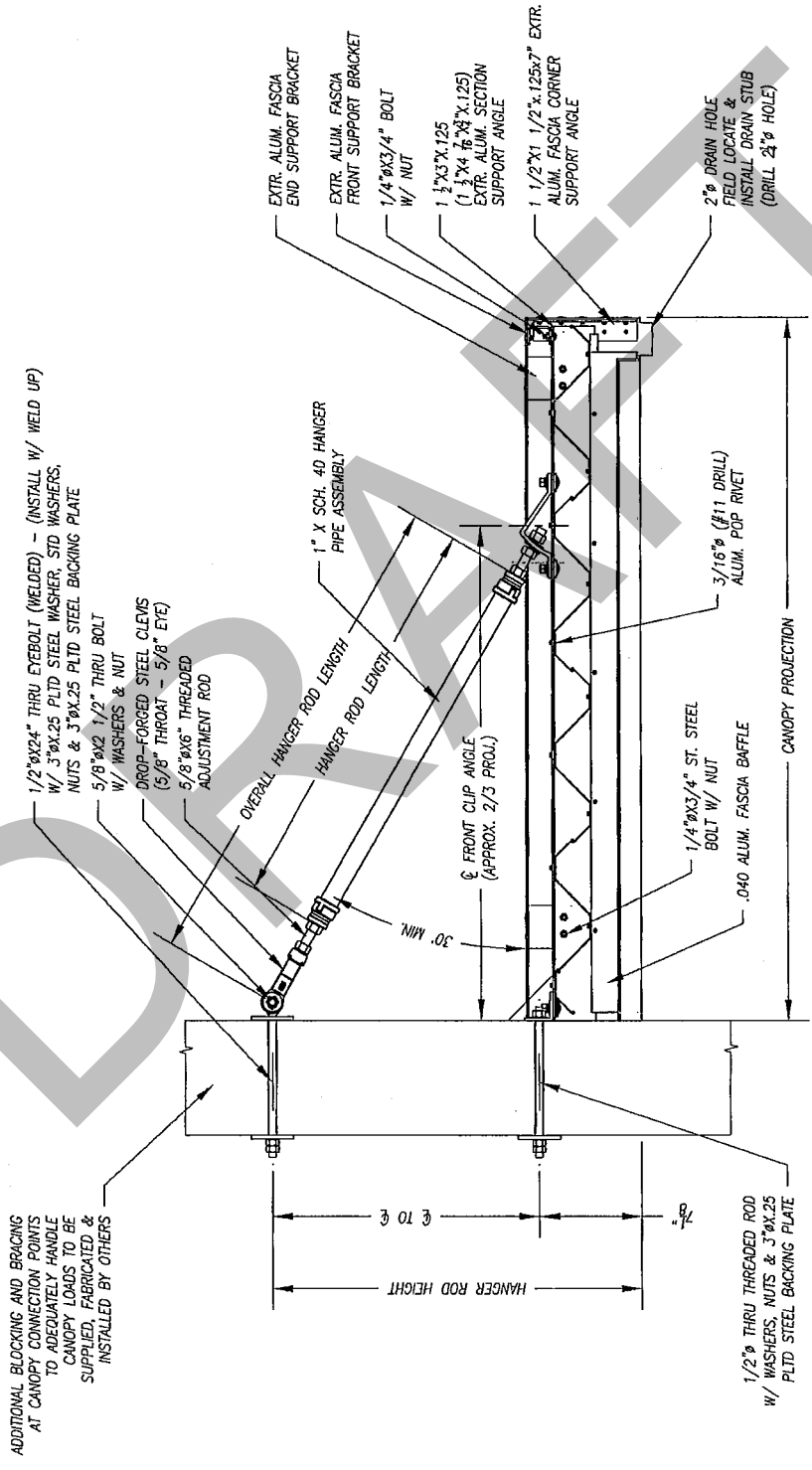

ADDITIONAL BLOCKING AND BRACING
 AT CANOPY CONNECTION POINTS
 TO ADEQUATELY HANDLE
 CANOPY LOADS TO BE
 SUPPLIED, FABRICATED &
 INSTALLED BY OTHERS

BB SECTION @ END CANOPY
 Scale: 1 1/2" = 1'-0"

Canopy Type:

Architect:

Drawn: 12/3/2019 BJW

Mapes Architectural Canopies
 7746 N. 56th St.
 Lincoln, NE. 68514-9724
 Ph: (888) 278-1132
 Fax: (877) 455-6572
 email: cad@mapes.com

Prepared for:
MAPES CANOPIES ()
 LINCOLN, NE

Job Name:
LUMESHADE HANGER ROD CANOPY / FRONT DRAINAGE

Rev # old
 MG #

Sheet: **09**
 Dec. 3, 19
 1 1/2" = 1'-0"
 of 10

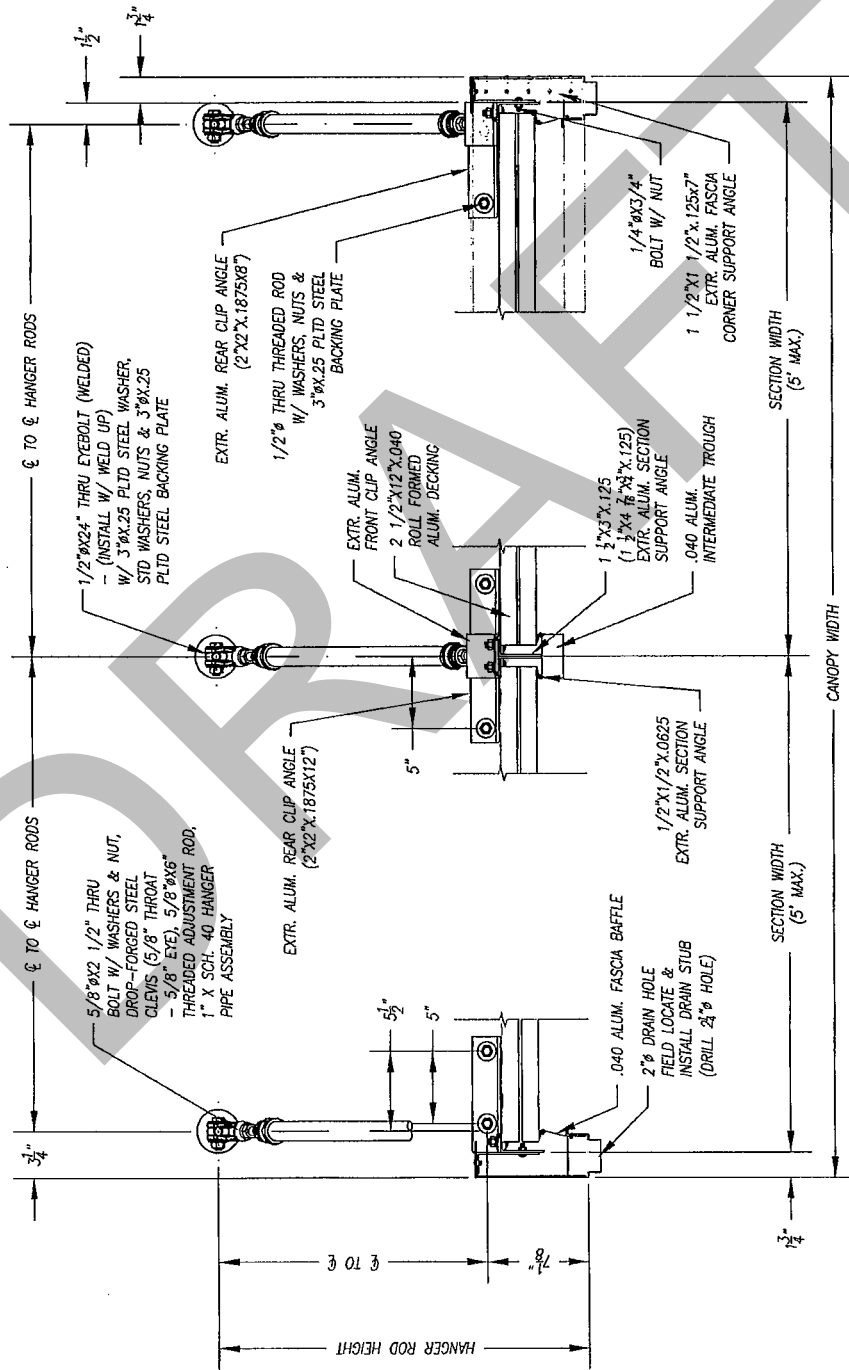

DD TRANSVERSE SECTION
 Scale: 1 1/2" = 1'-0"

SITE REFERENCE DIMENSIONS

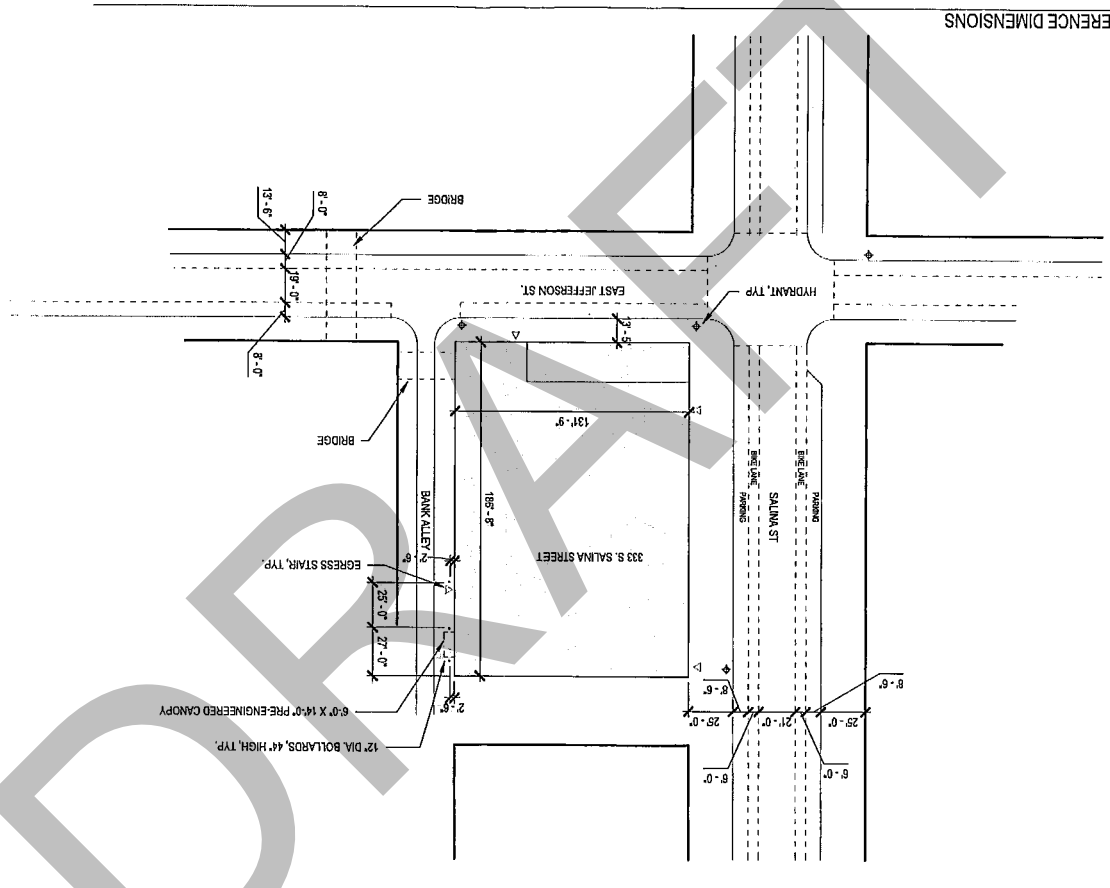

PROJECT: 115 ROOFTOP, LLC
 ADDITION FOR
 ROOFTOP BAR VERTICAL EXPANSION
 333 SOUTH SALINA ST. STRADDUCE, NJ 13222

DATE: 5/09/2023
 DRAWN BY: AMA
 SHEET NO: SITE01

20091-01
 PROJECT: 2023 - ASHLEY MCGRAW ARCHITECTS

ASHLEY MCGRAW



DEPARTMENT OF PUBLIC WORKS

CITY OF SYRACUSE, MAYOR BEN WALSH

238

Date 9-21-23

Jeremy Robinson
Commissioner

Patricia McBride
City Clerk
City Hall, Room 230
Syracuse, New York 13202

Ann Fordock
Deputy Commissioner

Martin E. Davis, L.S.
Deputy Commissioner

RE: Legislation Request – Permission for Encroachment *PC-0238-23*

Dear Ms. McBride:

Acropolis Center LLC is requesting an Encroachment Waiver for 4 concrete bollards that will encroach 2'6" into the Bank Alley Right-of-Way. The applicant's mailing address is as follows:

*115 E Jefferson St Suite 300
Syracuse NY 13202*

The proposed encroachment has been reviewed by various City departments and utility companies. Returned comments are enclosed. It appears that there is not major impediment to the request.

Please prepare legislation for consideration at the next meeting of the Common Council. Please let me know if you have any questions relative to this request.

Sincerely,

Jeremy Robinson
Commissioner of Public Works

Dept. of Public Works
1200 Canal St. Extension
Syracuse, N.Y. 13210

Office 315 448-2489
Fax 315 448-8531

www.syr.gov.net

ORDINANCE GRANTING PERMISSION TO ANDREA GOYETTE, PROPERTY OWNER OF 960 GLENCOVE ROAD, SYRACUSE NEW YORK TO ENCROACH UP TO 3'6" INTO THE GLENCOVE ROAD RIGHT-OF-WAY WITH NEW STONE STEPS AND DRAINAGE

WHEREAS, Scott Butler on behalf of Andrea Goyette, the owner of the property situated at 960 Glencove Road, Syracuse, New York, has requested permission to encroach up to 3'6" into the Glencove Road Right-of-Way with new stone steps and drainage; and

WHEREAS, the report of the Commissioner of the Department of Public Works is on file in the office of the City Clerk; NOW, THEREFORE,

BE IT ORDAINED, that this Common Council hereby grants permission to Andrea Goyette (hereinafter referred to as the "Owner") to maintain the aforementioned encroachment, subject to the following conditions:

1. The Owner shall defend, indemnify and save harmless the City of Syracuse, its officers and servants, from any and all liability and from any and all claims, damages, costs and expenses to person or property which may occur out of the usage of said street right-of-way heretofore described.

2. The Common Council may terminate this permission upon thirty (30) days notice to the Owner.

3. Said Owner, within thirty (30) days from the effective date of this ordinance, shall file in the office of the City Clerk a duly acknowledged written acceptance of this permission and consent to its terms and conditions. Said acceptance, when so filed, shall constitute an agreement on the part of the Owner to do and conform to all conditions thereof.

4. Said Owner shall obtain the necessary permits, in addition to this permission ordinance, for the new stone steps and drainage.

5. Said Owner agrees and consents that the City will not be liable for any damage to the new stone steps and drainage from any cause, including but not limited to snow removal, utility repair and replacement, and sidewalk repairs.

6. Said Owner agrees and consents to maintain compliance with the requirements of the various City Departments attached hereto as Appendix "A".

DRAFT

Appendix "A"



Department of Neighborhood & Business Development
Central Permit Office
 Ben Walsh, Mayor

Encroach (Minor) Plan Review Comments for Applicant (Revised 07/15)

Location of Proposed Work: 960 Glencove Rd & Mosley Dr

Permit #: PC-0350-23

Permit Type: Encroach (Minor)

Date: 09/21/2023

Contact: Scott Butler

Phone #: 315-559-9519

The departments below have reviewed your application and provided the following comments.
Approval is subject to the conditions listed below.

Approval	Status Date	Status	Reviewer	Comments
DPW - Commissioner	08/09/2023	Conditionally Approved	Martin Davis	Minor encroachment for steps. If the chain link fence is staying then that is also a Minor encroachment
DPW - Sanitation & Sewers	07/10/2023	Conditionally Approved	Vinny Esposito	Drain line can not daylight at a point that will cause runoff across the sidewalk or into the street. A level spreader type of recharge trench may be necessary.
DPW - Sidewalk Inspector	07/31/2023	Conditionally Approved	Chris Ettinger	no concerns
DPW - Traffic Control	07/14/2023	Conditionally Approved	Joe DiBello	no issues as long as prior approval from all reviewers
DPW - Transportation Planner	07/26/2023	Conditionally Approved	Neil Milcarek-Burke	1. Asphalt sidewalk is to be replaced to meet City spec 5' ADA compliant, concrete 2. Encroaching chain fence is to be removed from the City ROW 3. Encroaching features must be offset no less than 2' from the sidewalk, which this project must replace
Engineering - Design & Construction	07/13/2023	Conditionally Approved	Mirza Malkoc	<ul style="list-style-type: none"> • Proposed drain pipe from downspouts & rear drain pipe shall not discharge directly to the City's ROW. Property owner shall figure out a way where the stormwater from the roof and from the backyard is collected onsite and infiltrated on their property. As per the City's ordinance, property owner is not allowed to adversely impact the City's ROW & the adjoining properties. The applicant shall indemnify the City & assume all liability for any damages or injuries caused to, from or as a result of this encroachment, its installation & maintenance. • There shall not be any tripping hazards between the existing sidewalk and the proposed stone steps. • Property owner should consider replacing existing asphalt sidewalk with concrete sidewalk as part of this project. • Any sidewalk disturbed/damaged shall be replaced in full flags, all replacement sidewalks shall meet current ADA standards, and additional sidewalk may need to be removed to meet the standard. • All construction in the R.O.W. will require a permit, all construction in the R.O.W. to be per City standards and specifications. • Failure to adhere to City Standards & Permit requirements or ADA standards shall result in rejection & replacement of the work as ordered by the City Engineer, without question.
Engineering - Mapping	07/18/2023	Conditionally Approved	Ray Wills	-Applicant shall indemnify the City from and assume any and all liability for damages or injuries caused to, from or as a result of the approval of this encroachment. -Applicant understands that any encroachment approved is considered revokable at any time by the City.

-Applicant is responsible for maintaining the proposed encroachment ensuring the safety of any pedestrian traffic.
 -Stormwater runoff shall be collected on site and dispersed in an appropriate manner. DO NOT SHEET DRAIN STORMWATER TO CITY ROW.
 *The review approval is conditional. All encroachment final approval is contingent on the final approval of the Syracuse Common Council.

Engineering - Sewers	07/13/2023	Conditionally Approved	Mirza Malkoc	<ul style="list-style-type: none"> • Proposed drain pipe from downspouts & rear drain pipe shall not discharge directly to the City's ROW. Property owner shall figure out a way where the stormwater from the roof and from the backyard is collected onsite and infiltrated on their property. As per the City's ordinance, property owner is not allowed to adversely impact the City's ROW & the adjoining properties. The applicant shall indemnify the City & assume all liability for any damages or injuries caused to, from or as a result of this encroachment, its installation & maintenance. • Employ standard erosion and sediment control practices during construction. Clean and sweep pavement of all construction debris immediately. Stabilize all lawn areas within 7 days, seed and mulch. Maintain/ensure grass growth is established. No concrete washout, sediment, or construction debris shall enter catch basins or the sewer system. Any such occurrence shall be removed/cleaned immediately. • All disturbed areas shall be seeded & mulched until it reaches 80% grass growth.
Zoning Planner	09/15/2023	Not Applicable	Cristian Toelner	<p>Zoning does not regulate sidewalks or ROW. Expansion of proposed walking path would not exceed impervious surface coverage allowed within lot.</p>
Engineering - City Engineer	07/20/2023	Conditionally Approved	Mary Robison	<ul style="list-style-type: none"> • Proposed drain pipe from downspouts & rear drain pipe shall Not discharge directly to the City's ROW. Property owner shall figure out a way where the stormwater from the roof and from the backyard is collected onsite and infiltrated on their property. As per the City's ordinance, property owner is not allowed to adversely impact the City's ROW & the adjoining properties. Submit details of drainage pipe and how flow from pipe will be handled on the owner's property and will not adversely impact the adjoining neighbor or the street right of way - storm water flow shall not sheet flow across the sidewalk or directly into the street. •The applicant shall indemnify the City & assume all liability for any damages or injuries caused to, from or as a result of this encroachment, its installation & maintenance. • There shall not be any tripping hazards between the existing sidewalk and the proposed stone steps. Proposed stone steps cannot interfere with the public sidewalk. • Property owner should consider replacing existing asphalt sidewalk with concrete sidewalk as part of this project. • Any sidewalk disturbed/damaged shall be replaced in full flags, all replacement sidewalks shall meet current ADA standards, and additional sidewalk may need to be removed to meet the standard.

Department of Public Works

ENCROACHMENT PERMIT ROUTING FORM

ADDRESS: 960 Glencove Rd Syr: 13206

APPLICATION DATE: June 2023

PROPERTY: 027.-08-14.0

PERMIT APPLICATION: PC-0350-23

OWNER: Andrea Goyette

MINOR OR MAJOR ENCROACHMENT

CONTRACTOR:

PHONE: 315-559-9519

EMAIL: sbutler6@hotmail.com

DESCRIPTION OF WORK: Encroachment for new stone steps and drainage both encroaching 3'6" into the ROW

To:

ASSESSMENT	DPW	ENGINEERING	FIRE PREVENTION	LAW
NBD	PLANNING	POLICE	WATER	ZONING
DISTRICT COUNSILOR	CENTRO	NATIONAL GRID	VERIZON	

APPROVED/DENIED _____

REVIEWED BY _____ DATE _____

COMMENTS _____

This form is for the reviewing departments use only. Please do not return the Central Permit Office.

The applicant will receive the review comments that have been entered in IPS,

If you have any questions please call 315-448-47-15 or email centralpermitoffice@syr.gov.

Thank you

Encroachment Permit Instructions and Application

Jeremy Robinson
Commissioner



Ann Fordock
Deputy Commissioner

Martin E. Davis, L.S.
Deputy Commissioner

DEPARTMENT OF PUBLIC WORKS

Ben Walsh, Mayor

Encroachment Application and documents must be submitted to:

Central Permit Office
201 East Washington Street, Room 101
Syracuse, New York 13202, Phone # 315-448-4715
[CentralPermitOffice@syr.gov.net](mailto:CentralPermitOffice@syr.gov)

SUBMITTAL REQUIREMENTS

Only complete applications will be accepted for review:

- Pages 5 and 6 of the Encroachment Application completed in full and signed by the owner of the property adjacent to the right-of-way.
- A copy of the stamped survey map* (must be to scale, not reduced) for the private property abutting the street right-of-way in question.
- A stamped or signed site plan* (must be to scale, not reduced) showing specific location and distances from front of main building abutting right-of-way, front and side property lines, curbs, sidewalks, sidewalk widths, and driveways and improvement dimensions (lengths, widths, and heights) for all encroaching features. Also, for fencing, location of any gates and direction they will open. **The proposal can be drawn (to scale) on a copy of the property survey, but applicant must initial all changes made to the stamped survey and cross out the surveyor's stamp.**
- Elevation drawing* or manufacturer's catalogue cut of any features of the improvement.

*If you submit full size architectural drawings or survey maps, you must also submit one additional copy no larger than 11" x 17" or an electronic copy.

PLEASE FILL IN COMPLETELY

Address of Proposed Encroachment: 960 GLENCOVE ROAD SYRACUSE NY
Street address abutting the right-of-way where the improvement is being requested

Section, Block & Lot # (if known) _____

Property Owner (print name): ANDREA GOYETTE

Mailing Address (if different): 960 GLENCOVE ROAD SYRACUSE NY

Phone #(s): 315-559-9519

Email Address(es): SBUTLER6@HOTMAIL.COM

PC: 0350-23

Encroachment Permit Instructions and Application

Applicant / Owner's Representative (print name):

SCOTT BUTLER

Mailing Address:

960 GLENDALE ROAD SYRACUSE NY

Phone #(s):

315-559-9519

Email Address:

SBUTLER6@HOTMAIL.COM

Type of improvement requested:

NEW STONE STEPS AND WALKWAY

Describe the style &/or materials of the improvement:

STONE STEPS

Ex: a picket fence; a masonry bench

List the dimensions of the improvement in feet and inches:

Horizontal: 3 Feet 6 Inches Vertical: Feet Inches

What is the reason(s) for the improvement?

Specify any hardship or special circumstances, or public benefit to be gained, if applicable. Attach documentation or a letter of explanation if necessary.

Is this improvement part of a larger project?

Yes No X

If yes, please identify the project and specify the additional city/county approvals being applied for

How far does the feature encroach into the City's Right of Way?

STONE STEPS 3 FT 6 IN. DRAINAGE 3 FT 6 IN.

SIGNATURE OF THE OWNER

I (we) certify that I (we) own the private property listed above (i.e., the property abutting the requested improvement).

Signature(s):

[Signature] (OWNER'S REP)

6/23/23 Date

Date

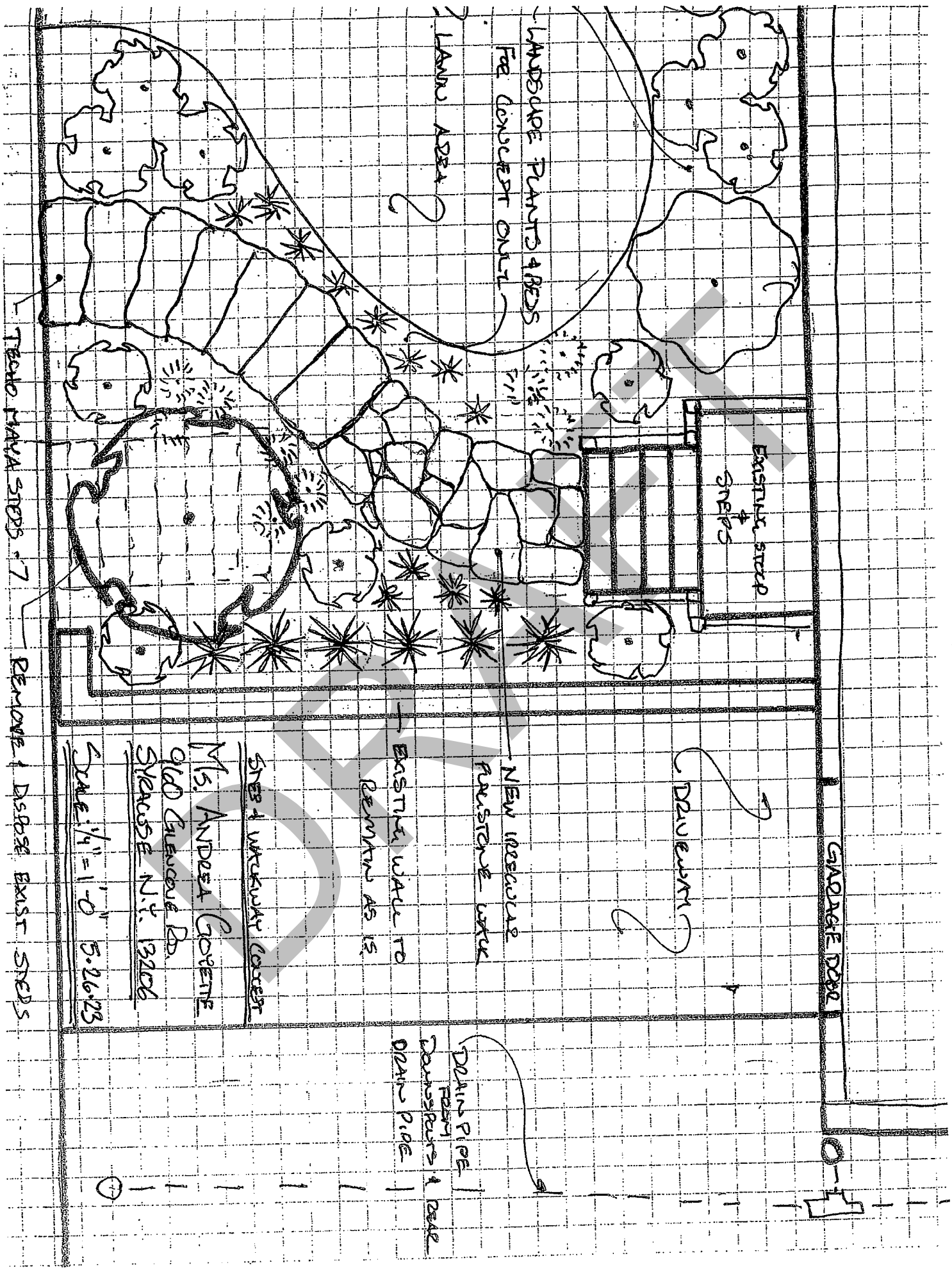

LANDSCAPE PLANTED AREAS FOR CONCRETE OUTFIT

LANDING AREA

EXISTING STAIRS

DRIVEWAY

GLAZED DOOR

NEW IRREGULAR POROUS CONCRETE

EXISTING WALL TO REMAIN AS IS

DRAIN PIPE FROM DOWNSPOUTS & GUTTER DRAIN PILE

STEP & WALKWAY CONCRETE

Mrs. ANDREA GOERTZ

Old GLENCOE RD.

SPRINGFIELD N.Y. 13206

SCALE: 1/4" = 1'-0" 5.26.23

TREAD WAY STAIRS

REMOVE & DISPOSE EXIST STAIRS



47

DEPARTMENT OF PUBLIC WORKS

CITY OF SYRACUSE, MAYOR BEN WALSH

Date 09-20-23

Jeremy Robinson
Commissioner

Ann Fordock
Deputy Commissioner

Martin E. Davis, L.S.
Deputy Commissioner

Patricia McBride
City Clerk
City Hall, Room 230
Syracuse, New York 13202

RE: Legislation Request – Permission for Encroachment *PC-0350-23*

Dear Ms. McBride:

Scott Buter on behalf of property owner Andrea Goyette is requesting an Encroachment Waiver for Stone Steps that encroach 3'6" into the Glencove ROW. The applicant's mailing address is as follows:

*960 Glencove Rd
Syracuse NY, 13206*

The proposed encroachment has been reviewed by various City departments and utility companies. Returned comments are enclosed. It appears that there is not major impediment to the request.

Please prepare legislation for consideration at the next meeting of the Common Council. Please let me know if you have any questions relative to this request.

Sincerely,

Jeremy Robinson
Commissioner of Public Works

Dept. of Public Works
1200 Canal St. Extension
Syracuse, N.Y. 13210

Office 315 448-2489
Fax 315 448-8531

www.syr.gov.net

GROWTH. DIVERSITY. OPPORTUNITY FOR ALL.

Ordinance No.

2023

**ORDINANCE GRANTING PERMISSION
TO HENRY ZURANSKI AND KAREN
ZURANSKI, PROPERTY OWNERS OF 202
LEAVENWORTH AVE, SYRACUSE NEW YORK
TO ENCROACH UP TO 45' INTO THE
LEAVENWORTH AVENUE RIGHT-OF-WAY
WITH AN EXISTING PARKING PAD**

WHEREAS, Henry Zuranski and Karen Zuranski, owners of the property situated at 202 Leavenworth Avenue, Syracuse, New York, have requested permission to encroach up to 45' into the Leavenworth Avenue Right-of-Way with an existing parking pad; and

WHEREAS, the report of the Commissioner of the Department of Public Works is on file in the office of the City Clerk; NOW, THEREFORE,

BE IT ORDAINED, that this Common Council hereby grants permission to Henry Zuranski and Karen Zuranski (hereinafter referred to as the "Owners") to maintain the aforementioned encroachment, subject to the following conditions:

1. The Owners shall defend, indemnify and save harmless the City of Syracuse, its officers and servants, from any and all liability and from any and all claims, damages, costs and expenses to person or property which may occur out of the usage of said street right-of-way heretofore described.

2. The Common Council may terminate this permission upon thirty (30) days notice to the Owners.

3. Said Owners, within thirty (30) days from the effective date of this ordinance, shall file in the office of the City Clerk a duly acknowledged written acceptance of this permission and

consent to its terms and conditions. Said acceptance, when so filed, shall constitute an agreement on the part of the Owners to do and conform to all conditions thereof.

4. Said Owners shall obtain the necessary permits, in addition to this permission ordinance, for the existing parking pad.

5. Said Owner agrees and consents that the City will not be liable for any damage to the existing parking pad from any cause, including but not limited to snow removal, utility repair and replacement, and sidewalk repairs.

6. Said Owner agrees and consents to maintain compliance with the requirements of the various City Departments attached hereto as Appendix "A".

DRAFT

Appendix "A"



Department of Neighborhood & Business Development
Central Permit Office
 Ben Walsh, Mayor

Encroach (Minor) Plan Review Comments for Applicant
 (Revised 07/15)

Location of Proposed Work: 202 Leavenworth Ave

Permit #: PC-0157-23

Permit Type: Encroach (Minor)

Date: 09/21/2023

Contact: Henry Robert Zuranski

Phone #: 315-278-1889

The departments below have reviewed your application and provided the following comments.
Approval is subject to the conditions listed below.

Approval	Status Date	Status	Reviewer	Comments
DPW - Commissioner	04/20/2023	Approved	Martin Davis	No issue with existing parking September 12,2023 - Homeowner will install a new concrete sidewalk at owners expense for the width (40') . Homeowner will acquire all permits necessary for repair/ resurface of existing driveway and maintain a buffer between adjoining property's and self contain all surface runoff from the paved area.
DPW - Sanitation & Sewers	05/10/2023	Conditionally Approved	Vinny Esposito	this lot should never have been allowed. the entire front yard is paved contributing to drainage issues. It is also a dangerous situation with pedestrians. 5/10/23 This pavement has been in place for years. Utility service access must be restored per code(sewer vent and CO,water curb stop,gas box). Sidewalk must be restored in concrete per code.
DPW - Sidewalk Inspector	09/11/2023	Approved	Chris Ettinger	
DPW - Traffic Control	05/18/2023	Conditionally Approved	Joe DiBello	no issue
DPW - Transportation Planner	04/13/2023	Internal Review Complete	Neil Milcarek-Burke	Parking in the proposed/existing configuration poses a major impediment to proper access control, pedestrian safety, and typical allowances for residential driveways. This item is suggested to be denied outright.
Engineering - Design & Construction	06/15/2023	Conditionally Approved	John Kivlehan	Zoning prohibits parking in the front plane of buildings, however in this case the the front plane is predominately City ROW however guidance from zoning should be considered. As such the Dept. of Eng. would be agreeable to allowing one parking spot in the front plane based on the standard driveway width of 12', also additional existing blacktop then on site shall be removed and the area restored as lawn. Other vehicles will have to use on street parking. Only one vehicle allowed to encroach for parking in the ROW
Engineering - Mapping	05/18/2023	Not Applicable	Ray Wills	45'x40' is a very substantial encroachment. Parking in such close proximity to the sidewalk, and the hedge row to the north poses a significant risk to pedestrian and vehicular traffic. Line of sight is almost complete blocked, exiting the driveway without blocking the sidewalk is not possible. That being said, proposal itself would have no direct impact on in ground Mapping assets. Deferring to Design and Construction, DPW & The City Engineer.
Engineering - Sewers	06/15/2023	Conditionally Approved	John Kivlehan	See comments from design and construction,. This area should be treated/considered as the front plane of a residential property as such the asphalt area between the building and sidewalk

should be lawn. The building already occupies the entire lot and has minimal to zero stormwater runoff benefit. allowing additional impervious surfaces as part of this encroachment only adds to run off concerns. As suggested, the Dept. of Eng. is agreeable to only one vehicle being allowed to park in the ROW and it shall be limited to a 12' wide area of asphalt, all other asphalt shall be removed and the area restored to lawn to reduce stormwater runcff

Zoning Planner	09/15/2023	Not Applicable	Cristian Toellner	Parking in the front yard setback without an approved area variance from the BZA is illegal. Zoning would not encourage parking in the front yard setback. On-street parking within 1,000 linear feet of the property is permitted via Zoning Administrator approval, and would replace minimum off-street parking requirements. Defer to other departments for comment.
----------------	------------	----------------	-------------------	--

DRAFT

Department of Public Works

ENCROACHMENT PERMIT ROUTING FORM

ADDRESS: 202 Leavenworth Ave Syracuse, 13204

APPLICATION DATE: 4-13-23

PROPERTY: 106.-12-15.0

PERMIT APPLICATION: PC-0157-23

OWNER: Henry & Karen Zuranski

MINOR OR MAJOR ENCROACHMENT

CONTRACTOR:

PHONE: 315-278-1889

EMAIL: karencoyles56@gmail.com

DESCRIPTION OF WORK: Seeking encroachment waiver for existing parking pad that encroaches 45' into ROW

To:

ASSESSMENT

DPW

ENGINEERING

FIRE PREVENTION LAW

NBD

PLANNING

POLICE

WATER

ZONING

DISTRICT COUNSILOR

CENTRO

NATIONAL GRID

VERIZON

APPROVED/DENIED _____

REVIEWED BY _____

DATE _____

COMMENTS _____

This form is for the reviewing departments use only. Please do not return the Central Permit Office.

The applicant will receive the review comments that have been entered in IPS.

If you have any questions please call 315-448-47-15 or email centralpermitoffice@syr.gov.

Thank you

Encroachment Permit Instructions and Application

Jeremy Robinson
Commissioner

Martin E. Davis, L.S.
Deputy Commissioner



Ann Fordock
Deputy Commissioner

DEPARTMENT OF PUBLIC WORKS

Ben Walsh, Mayor

Encroachment Application and documents must be submitted to:

Central Permit Office
201 East Washington Street, Room 101
Syracuse, New York 13202, Phone # 315-448-4715
[CentralPermitOffice@syr.gov.net](mailto:CentralPermitOffice@syr.gov)

SUBMITTAL REQUIREMENTS

Only complete applications will be accepted for review:

- Pages 5 and 6 of the Encroachment Application completed in full and signed by the owner of the property adjacent to the right-of-way.
- A copy of the stamped survey map* (**must be to scale**, not reduced) for the private property abutting the street right-of-way in question.
- A stamped or signed site plan* (**must be to scale**, not reduced) showing specific location and distances from front of main building abutting right-of-way, front and side property lines, curbs, sidewalks, sidewalk widths, and driveways and improvement dimensions (lengths, widths, and heights) for all encroaching features. Also, for fencing, location of any gates and direction they will open. **The proposal can be drawn (to scale) on a copy of the property survey, but applicant must initial all changes made to the stamped survey and cross out the surveyor's stamp.**
- Elevation drawing* or manufacturer's catalogue cut of any features of the improvement.

**If you submit full size architectural drawings or survey maps, you must also submit one additional copy no larger than 11" x 17" or an electronic copy.*

PC 0157. 23

PLEASE FILL IN COMPLETELY

Address of Proposed Encroachment:

202 Leavenworth Ave Syracuse NY 13204
Street address abutting the right-of-way where the improvement is being requested

Section, Block & Lot # (if known)

Property Owner (print name):

Henry + Karen Zuranski

Mailing Address (if different):

Phone #(s):

315 278-1889

Email Address(es):

karencoyle56@gmail.com

Encroachment Permit Instructions and Application

Applicant / Owner's Representative
(print name):

Karen Zuranski

Mailing Address:

202 Leavenworth Ave

Phone #(s): 315-278-1889

Syracuse NY 13204

Email Address:

karencoyle56@gmail.com

Type of improvement requested:

retar via (resurface existing parking pad

Describe the style &/or materials of the improvement:

Resurface parking pad

Ex: a picket fence; a masonry bench

List the dimensions of the improvement in feet and inches:

Horizontal:

Feet Inches

Vertical:

Feet Inches

What is the reason(s) for the improvement?

Resurface parking pad to ensure no one falls trips + improve appearance of property

Specify any hardship or special circumstances, or public benefit to be gained, if applicable. Attach documentation or a letter of explanation if necessary.

Is this improvement part of a larger project?

Yes

X

No

If yes, please identify the project and specify the additional city/county approvals being applied for

How far does the feature encroach into the City's Right of Way?

Parking area - 45 feet

SIGNATURE OF THE OWNER

I (we) certify that I (we) own the private property listed above (i.e., the property abutting the requested improvement).

Signature(s):

Karen Zuranski

4/12/23

Date

Date

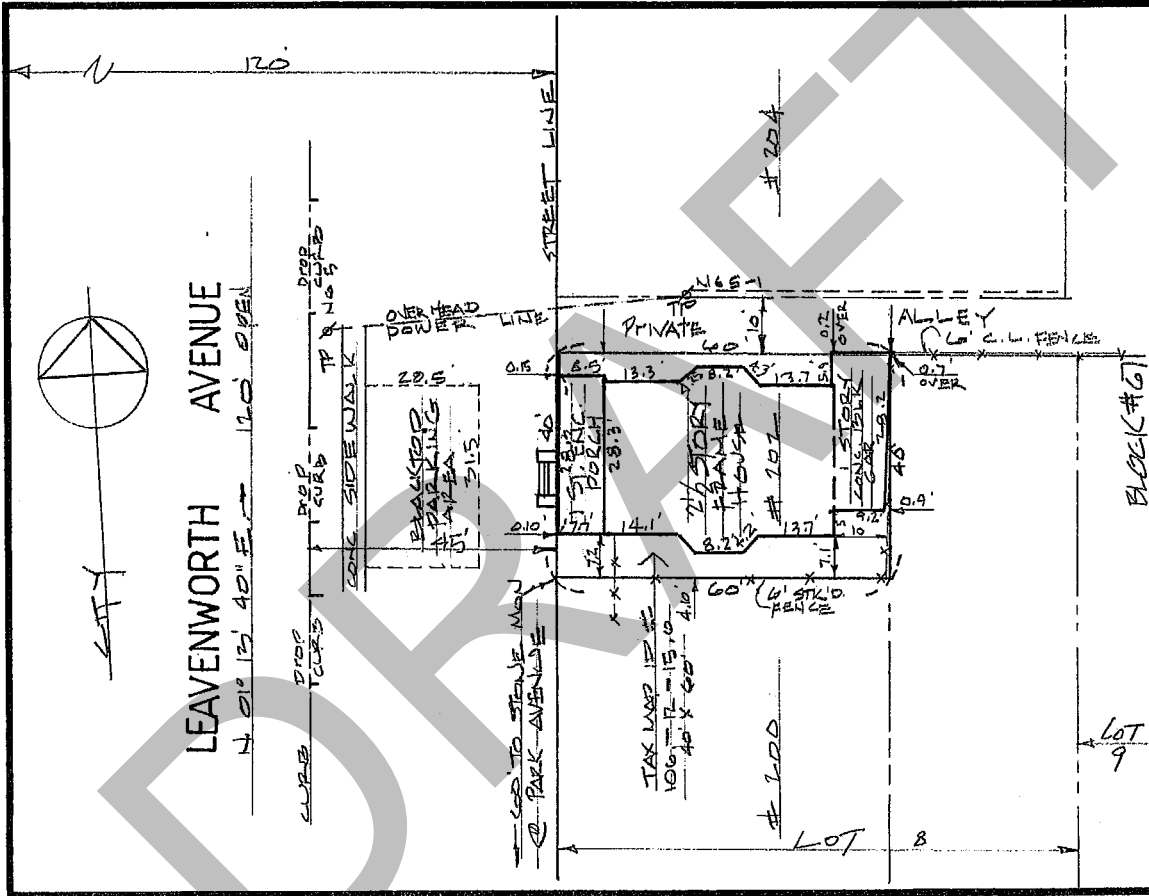

	DRAWN BY: MD	DATE: 4/08/23	SCALE: 1" = 20'	REVISIONS:
	Location Survey on part of Lot #8, Block 67 City of Syracuse, County of Onondaga and State of New York. Known as #202 Leavenworth Avenue. THE UNDERSIGNED SURVEYOR HEREBY CERTIFIES THAT THIS IS AN ACCURATE MAP OF AN ACTUAL SURVEY MARTIN E. DAVIS 409 RIDGEMOOD DRIVE LICENSED LAND SURVEYOR SYRACUSE, NEW YORK			



DEPARTMENT OF PUBLIC WORKS

CITY OF SYRACUSE, MAYOR BEN WALSH

Date 9-21-23

Jeremy Robinson
Commissioner

Ann Fordock
Deputy Commissioner

Martin E. Davis, L.S.
Deputy Commissioner

Patricia McBride
City Clerk
City Hall, Room 230
Syracuse, New York 13202

RE: Legislation Request – Permission for Encroachment *PC-0157-23*

Dear Ms. McBride:

Henry and Karen Zuranski are requesting an Encroachment Waiver for their existing parking area that encroaches 45' into the Leavenworth Ave Right-of Way. The applicant's mailing address is as follows:

202 Leavenworth Ave
Syracuse, NY 13204

The proposed encroachment has been reviewed by various City departments and utility companies. Returned comments are enclosed. It appears that there is not major impediment to the request.

Please prepare legislation for consideration at the next meeting of the Common Council. Please let me know if you have any questions relative to this request.

Sincerely,

Jeremy Robinson
Commissioner of Public Works

Dept, of Public Works
1200 Canal St. Extension
Syracuse, N.Y. 13210

Office 315 448-2489
Fax 315 448-8531

www.syr.gov.net