



# CITY OF SYRACUSE PUBLIC ART APPLICATION

**Project Title:** \_\_\_\_\_

**Installation Type:**

- \_\_\_\_\_ Donation to permanent art collection
- \_\_\_\_\_ Temporary installation
- \_\_\_\_\_ Proposed date and duration of installation: \_\_\_\_\_
- \_\_\_\_\_ Mural on private property

**Installation Location**

**Property Name:** \_\_\_\_\_

**Street Address:** \_\_\_\_\_

**Location Description [e.g., 15 ft. from building entrance]:** \_\_\_\_\_

**Artwork Type [e.g., sculpture, mural, video]:** \_\_\_\_\_

**Artwork Description [include fabrication date; medium, dimensions, materials and finishes]:**

\_\_\_\_\_

\_\_\_\_\_

\_\_\_\_\_

\_\_\_\_\_

**Artist**

**Name:** \_\_\_\_\_

**Address:** \_\_\_\_\_

**Phone:** \_\_\_\_\_

**Email:** \_\_\_\_\_

**Current Owner (if applicable)**

**Name:** \_\_\_\_\_

**Address:** \_\_\_\_\_

**Phone:** \_\_\_\_\_

**Email:** \_\_\_\_\_

**Applicant**

**Name:** \_\_\_\_\_

**Address:** \_\_\_\_\_

**Phone:** \_\_\_\_\_

**Email:** \_\_\_\_\_

**Signature:** \_\_\_\_\_ **Date** \_\_\_\_\_

# Syracuse Writers

## 17 Authors

Jermaine Loguen  
George Schuyler  
John Williams  
Toni Morrison  
Safiya Henderson-Holmes  
Elizabeth Cotton  
Matilda Jocelyn Gage  
Shirley Jackson  
Joyce Carol Oates  
Daniel Berrigan  
Joanne Shenedoah  
F. Scott Fitzgerald  
Minnie Bruce Pratt  
L. Frank Baum  
Lou Reed  
Rod Serling  
Raymond Carver

# SYRACUSE WRITERS PROJECT DESCRIPTION

Syracuse, NY, has a rich and proud legacy of being home to many authors, poets, and writers who have made important contributions to the world of literature, poetry, playwriting, and more. It's time we celebrate that legacy and acknowledge those writers, past and present.

The Syracuse Writers Project proposes to install a series of larger-than-life panels on the Connective Corridor that celebrate the writers of Syracuse by displaying their names and a short passage from their work.

The purpose of this project is to educate and inspire Syracuse residents and visitors and expand our understanding of the City where we live and the writings of these talented and often historically meaningful writers. We have an opportunity to create something truly unique for our city that celebrates those whose work continues to enlarge the lives of others all over the world.

The team identified more than 120 such writers who have an association with Syracuse. We acknowledge that we did

not capture everyone worthy of being included. Due to project funding limitations, we will ultimately have to initially limit the writers we display to about 18 individuals. To narrow our list down from 120 to 17-18 for the initial installment we sought the input of the writing community. We feel it is important to ensure that this first installation be inclusive and representative of a broad coalition of diverse voices and genres. We asked that people complete a survey with that intention in mind. We did not receive a lot of responses but the ones we did get were thoughtful and helped us develop our proposed list of writers and an initial pass at possible selections of writing.

## Design

The panel design is an evolution of an idea that began a few years ago. Our proposal is to utilize the steel posts of the failing Forman Park "USE" fence to remake it into a Syracuse Writers wall. We do not have the budget to replace every panel in the fence today, so we see our installation as the first step in transformation. We will remove 6-7 20"x10' mesh panels and replace them with

20"x10' laser cut aluminum sheets with a solid backer panel. Each assembly will be secured to 3 of the existing steel posts with aluminum angles- making for a ridged and durable installation. The mesh panels that we remove can be used to replace 6-7 other mesh panels on the fence that are currently damaged. At last count there are approximately 10 severely damaged mesh panels, so this method will go a long way to reviving the current conditions.

## Looking to the future

We envision and hope that this installation is just the start. We have designed the panels in a way that can be easily replicated and added to the Forman Park Fence as funding becomes available. Each time a panel is added, the mesh can be discarded or used to replace a failing section until the entire fence is replaced with the quotes and passages of Syracuse Writers. Our hope is also that eventually a web-based resource will accompany the physical installation and build on the pages by housing more complete works, links, and resources and can expand over time.

# PROJECT LOCATION

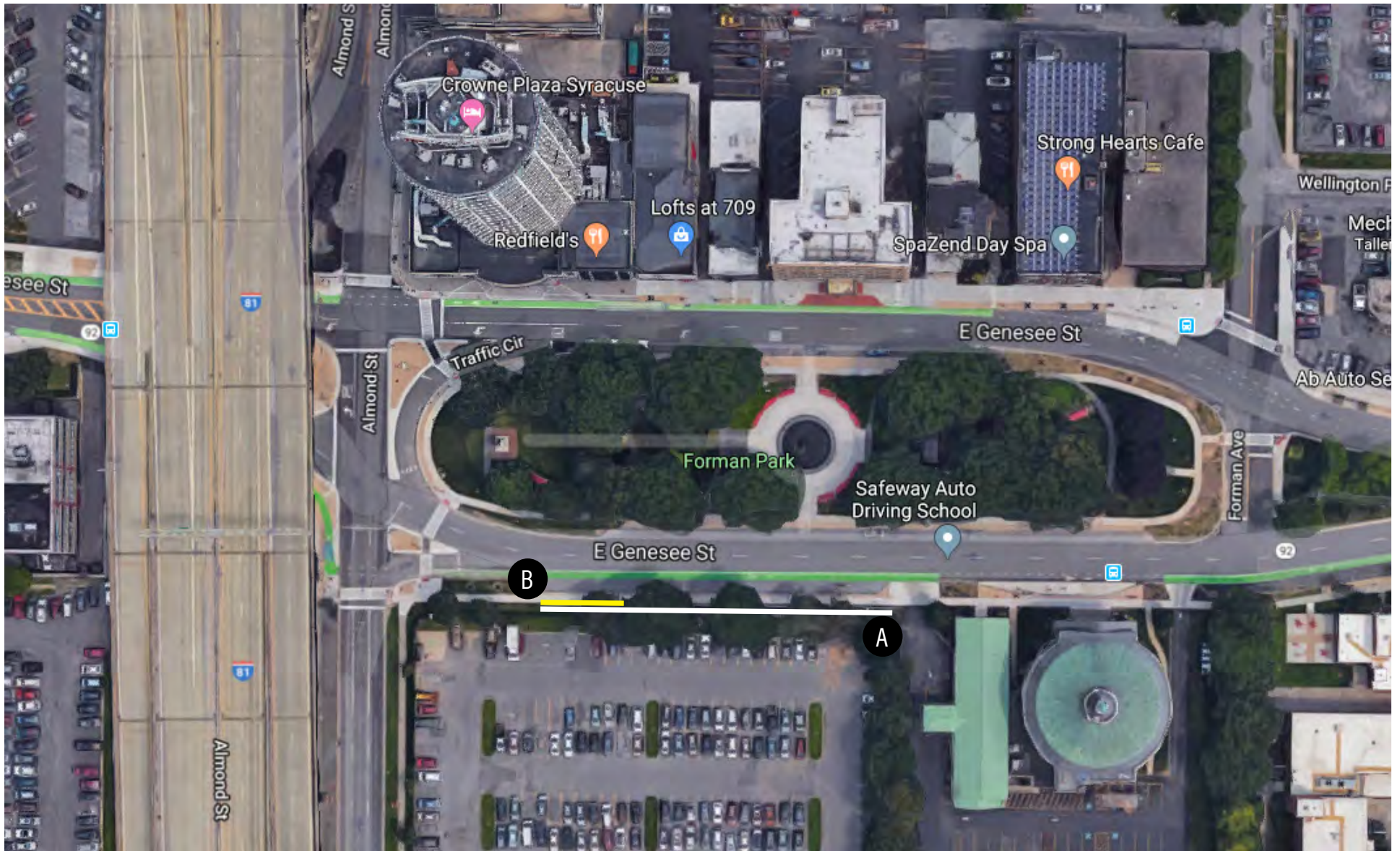

**A** 240' length of Forman Park Fence

**B** Aprox. 70' length of Installation

## **SELECTED WRITERS**

Jermaine Loguen

George Schuyler

John Williams

Toni Morrison

Safiya Henderson-Holmes

Elizabeth Cotton

Matilda Jocelyn Gage

Shirley Jackson

Joyce Carol Oates

Daniel Berrigan

Joanne Shenedoah

F. Scott Fitzgerald

Minnie Bruce Pratt

L. Frank Baum

Lou Reed

Rod Serling

Raymond Carver

## **SHORT AND LONG-TERM MAINTENANCE REQUIREMENTS**

The Syracuse Writers Panels should require very little to no maintenance. The panels are constructed of aluminum so will not succumb to rust. The colored sections are north facing, so will have little direct sun exposure, which means less fading of color. The connection points will have insulated washers to reduce or eliminate problems caused by contact between steel and aluminum. The only points of failure would be adhesion between panels if we use a metal adhesive. This can be solved by mechanically fastening the panels. And bolts may need to be tightened at some point in the future.

## **PROJECT TIMELINE**

Funding must be utilized by September 2019 or it will be lost.

June/July- Public Art Commission Approval

July/August- Common Council Approval

August/ September- Fabrication and Installation. Fabrication will take approximately 5 weeks. Installation should be 1-2 days.

## **BUDGET**

The Syracuse Writers Project is funded by NYS grants distributed through Syracuse University to be utilized exclusively on the Connective Corridor. Our funding for this portion of the project is roughly \$30,000 which includes final design, fabrication, delivery, and installation. Raw fabrication alone costs approximately \$2,500 per panel.

# EXISTING CONDITIONS



Total of 6-7 mesh panels removed and available to replace sections of damaged mesh.



Total of 10 very damaged mesh panels.

- A** Most of the 240' length of the Forman Park Fence
- B** Section where installation is proposed- Mesh panels are in good condition
- C** Section where damaged mesh can be replaced
- D** Section where damaged mesh can be replaced

# EXISTING FENCE DESIGN



# NEW PANELS: DESIGN (NOT SHOWING FINAL TEXT)

SYRACUSE WRITERS FENCE  
LOCUS | 14 MAY 2019



COME out . . . . out  
To this inevitable night of mine  
Oh you drinker of new wine,  
Here's pageantry  
Here's carnival, Rich dusk,  
dim streets and all  
The whispering of city night.

COME out . . . . out  
To this inevitable night of mine  
Oh you drinker of new wine,  
Here's pageantry  
Here's carnival, Rich dusk  
AUTHOR  
(18XX-19XX)

COME out . . . . out  
To this inevitable night of mine  
Oh you drinker of new wine,  
Here's pageantry  
Here's carnival, Rich dusk,  
dim streets and all  
The whispering of city night.

COME out . . . . out  
To this inevitable night of mine  
Oh you drinker of new wine

AUTH  
(18XX-19XX)

SYRACUSE WRITERS



**EXISTING FENCE**



# 6 NEW PANELS: DESIGN (NOT SHOWING FINAL TEXT)





# NEW PANELS: MATERIALS & MOUNTING DETAIL

SYRACUSE WRITERS FENCE  
LOCUS | 06 JUNE 2019

TYPICAL REPLACEMENT PANEL

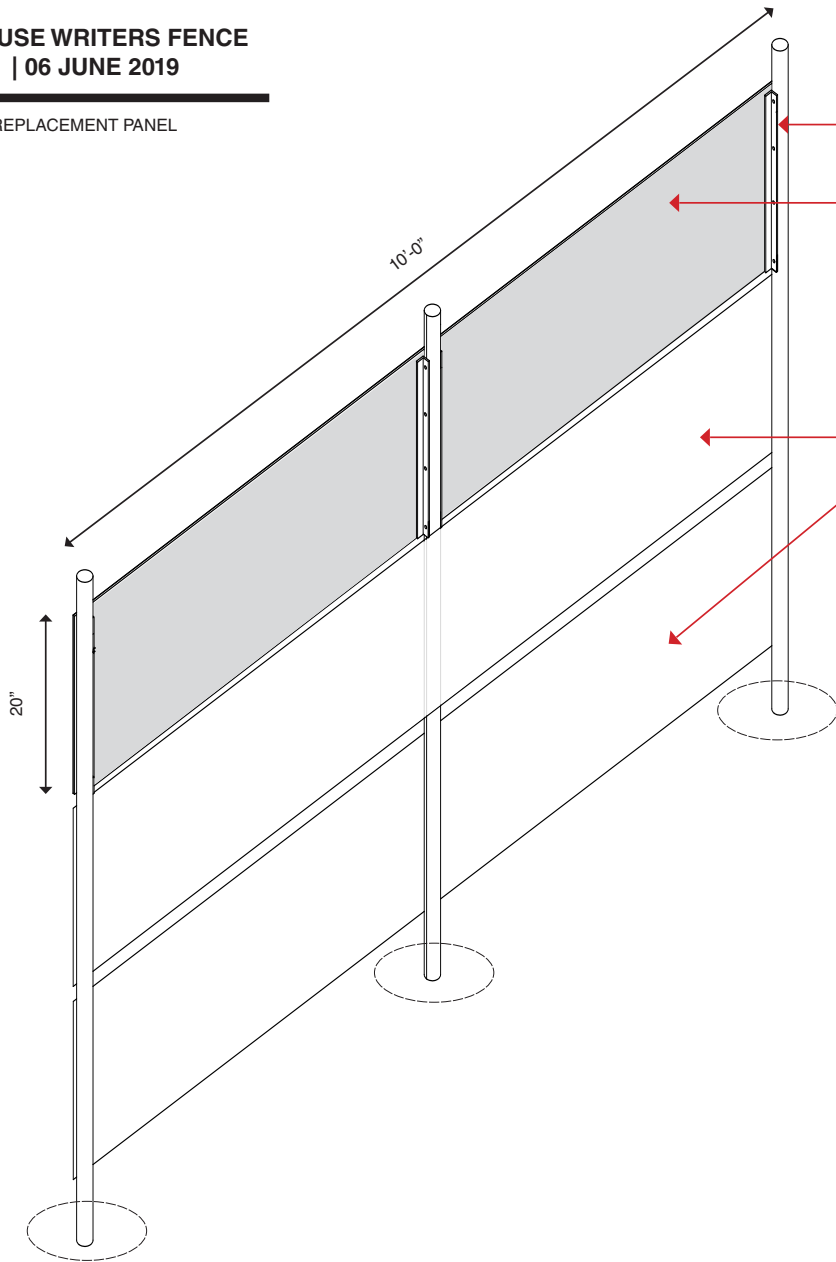

(4) 2" X 2" .125 ALUM ANGLE (MIN)  
WELD TO ALUM BACK PLATE.  
BOLT TO EXISTING VERTICAL STEEL POLES WITH  
INSULATING WASHERS BETWEEN POLE AND ANGLE

REMOVE EXISTING 20"X120" MESH PANEL AND REPLACE  
WITH:  
(1) LAYER .08 ALUMINUM SHEET WITH LASER-CUT TEXT  
ADHERED TO  
(1) LAYER .06 POWERCOATED ALUMINUM SHEET

EXISTING MESH PANELS TO REMAIN

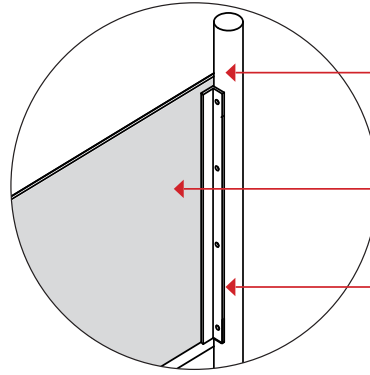

EXISTING 2" GALVANIZED  
STEEL POST

(1) LAYER .08 ALUMINUM  
SHEET WITH LASER-CUT TEXT  
ADHERED TO  
(1) LAYER .06 POWERCOATED  
ALUMINUM SHEET

2" X 2" .125 ALUM ANGLE (MIN)  
WELD TO ALUM BACK PLATE.  
BOLT TO EXISTING VERTICAL  
STEEL POLES WITH  
INSULATING WASHERS  
BETWEEN POLE AND ANGLE

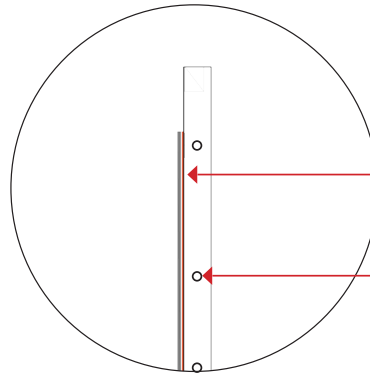

REMOVE EXISTING MESH AND  
REPLACE WITH  
(1) LAYER .08 ALUMINUM  
SHEET WITH LASER-CUT TEXT  
ADHERED TO  
(1) LAYER .06 POWERCOATED  
ALUMINUM SHEET

BOLT THROUGH EXISTING  
STEEL POST WITH  
INSULATING WASHERS  
BETWEEN POST AND ANGLE

SECTION

## **SYRACUSE WRITERS AND THEIR WORDS**

Many authors, poets, and writers who have made important contributions to the world of literature, poetry, playwriting, and more have made Syracuse NY their home.

Let's celebrate their legacy, acknowledge our diversity and remember the words of our writers, past and present.

-Started in 2019, this ongoing installation will continue adding panels to the fence over time.

---

"My neighbors! I have lived with you many years, and you know me. My home is here, and my children were born here. I am bound to Syracuse by pecuniary interests, and social and family bonds. And do you think I can be taken away from you and from my wife and children, and be a slave in Tennessee?"

**Jermain Loguen (1813-1872)**  
***Stationmaster of the Underground Railroad***

"Do not allow the Church or State to govern your thought or dictate your judgment."

**Matilda Joslyn Gage (1826-1898)**  
***Born with a hatred of oppression***

"Writers don't need tricks or gimmicks or even necessarily need to be the smartest fellows on the block. At the risk of appearing foolish, a writer sometimes needs to be able to just stand and gape at this or that thing- a sunset or an old shoe- in absolute and simple amazement."

**Raymond Carver (1938- 1988)**  
***Master of the Short Story***

“Definitions belong to the definers, not the defined.”

**Toni Morrison (b. 1931)**

***Nobel Laureate who began writing as a single mother in Syracuse***

“Because we want the peace with half a heart and half a life and will, the war, of course, continues, because the waging of war, by its nature, is total - but the waging of peace, by our own cowardice, is partial.”

**Daniel Berrigan (1921-2016)**

***Priest, poet and peace and human rights activist***

“So often, the Syracuse sky was overcast and glowering, as if with withheld secrets, passions. Clouds were never two-dimensional like painted scenery but massed, massive, bulging, tumescent, pocked and pitted and creviced and boiling, rarely white, rarely of a single hue, but infinitely varied shades of gray, dark-gray, powder-gray, bruise-gray, iron-gray, purple gray, shot with a mysteriously advancing, and abruptly fading, sunlight. Rain was falling, or had recently fallen leaving everything slick, wet, shining, washed-clean; sullen, punished-looking; or gleaming with optimism, hope.”

**Joyce Carol Oates (b. 1938)**

***Upstate's Novelist***

“An old man, crippled and torn  
Came to us looking for bread and corn  
He was unsightly and needed some care  
Nobody helped him, no one dared

Wolf, turtle or bear? Who gave him food?  
Who clothed his back? A bear woman was good  
Little light, both day and night  
Took care of the old man all day and night”

**Joanne Shenandoah (b. 1958)**  
*Musical voice of the Haudenosaunee*

“First thing you learn  
is that you've always got to wait. “

**Lou Reed (1942-2013)**  
*Rock and Roll Animal*

“I have always loved to use fear, to take it and comprehend it and make it work and consolidate a situation where I was afraid and take it whole and work from there.”

**Shirley Jackson (1916-1965)**  
*Master of Gothic Fantasy and Fiction*

“Ashamed, people turned their faces away  
from the woman ranting, asking: Justice,  
stretch out your hand. Come down, glittering,  
from where you have hidden yourself away.”

**Minnie Bruce Price (b. 1946)**  
*Poet and Lesbian activist*

“There are weapons that are simply thoughts, attitudes, and prejudices, to be found only in the minds of men. For the record, prejudices can kill and suspicion can destroy ... The pity of it is, these things cannot be confined to the Twilight Zone.”

**Rod Serling (1924-1974)**

***You are entering the Twilight Zone***

“I never saw any colored person in any position of authority in Syracuse until the U.S. Army held maneuvers in the area around 1909, and several companies of Negro soldiers were camped in a large park where traveling circuses usually performed. The black infantrymen and cavalymen were something else again. We were impressed by their superb order and discipline, their haughty and immaculate noncommissioned officers, and their obvious authority. The only colored men in uniform that we had seen were our fathers in the uniforms of the Knights of Pythias and the Odd Fellows, and they were simply ludicrous, representing nothing.”

**George Schuyler (1895-1977)**

***Satiric Writer of the Harlem Renaissance and a Voice of Black Conservatism***



“But the Ward was not always black and it was not always unhappy. Many kinds of people lived there, Negroes, Jews, Italians, Irish, Poles, Indians and “native Americans.” The people shared conversation and other small joys. The religious holidays of all were greatly respected. If your parents were at work or shopping someone on the block had his or her eye on you. In the Ward survival of the other fellow and his children meant survival for you. For me, the Ward was home and the rest of Syracuse radiated outward from it. It was a city within a city and at dusk the year around, you could see men of all sizes, shapes and colors returning to it from their jobs, such as they were.”

**John Williams (1925 – 2015)**

***Writer of the Second Harlem Renaissance; Raised in Syracuse’s 15<sup>th</sup> Ward***

“So we beat on, boats against the current, borne back ceaselessly into the past.”

**F. Scott Fitzgerald (1896-1940)**

***America’s Novelist***

“Freight train, freight train, going so fast  
Freight train, freight train, going so fast  
Please don't tell what train I'm on  
So they won't know where I'm gone.

Freight train, freight train, going round the bend  
Freight train, freight train, gone again  
One of these days turn that train around”

**Elizabeth Cotten (1893 –1987)**

***Grandmother of the Blues***

“That proves you are unusual," returned the Scarecrow; "and I am convinced that the only people worthy of consideration in this world are the unusual ones. For the common folks are like the leaves of a tree, and live and die unnoticed.”

**L. Frank Baum (1856-1919)**

***America's first fantasy writer, author of the "Wonderful Wizard of Oz"***

“These narratives are an attempt to fill my body and soul. To seduce myself, lick my own heart, gather memories like flowers and fireflies, bring every piece of me to the bedroom of my skin and not be afraid of love - even now. Even now.”

**Safiya Henderson-Holmes (1950-2001)**

***A soulful poet writing through adversity***

**“My neighbors! I have lived with you many years, and you know me. My home is here, and my children were born here. I am bound to Syracuse by pecuniary interests, and social and family bonds. And do you think I can be taken away from you and from my wife and children, and be a slave in Tennessee?”**

**Jermain Loguen (1813-1872)  
Stationmaster of the Underground Railroad**

**“Do not allow the Church or State to govern your thought or dictate your judgment.”**

**Matilda Joselyn Gage (1826-1898)  
Born with a hatred of oppression**

**“Writers don’t need tricks or gimmicks or even necessarily need to be the smartest fellows on the block. At the risk of appearing foolish, a writer sometimes needs to be able to just stand and gape at this or that thing- a sunset or an old shoe- in absolute and simple amazement.”**

**Raymond Carver (1938- 1988)  
Master of the Short Story**

## **SYRACUSE WRITERS AND THEIR WORDS**

**Many authors, poets, and writers who have made important contributions to the world of literature, poetry, playwriting, and more have made Syracuse Ny their home. Let’s celebrate their legacy, acknowledge our diversity and remember the words of our writers, past and present.**

**-Started in 2019, this ongoing installation will add panels to the fence over time.**

**“Definitions belong to the definers, not the defined.”**

**Toni Morrison (b. 1931)  
Nobel Laureate who began writing  
as single mother in Syracuse**

**“Because we want the peace with half a heart and half a life and will, the war, of course, continues, because the waging of war, by its nature, is total - but the waging of peace, by our own cowardice, is partial.”**

**Daniel Berrigan (1921-2016)  
Priest, poet and peace and human rights  
activist**

**“So often, the Syracuse sky was overcast and glowering, as if with withheld secrets, passions. Clouds were never two-dimensional like painted scenery but massed, massive, bulging, tumescent, pocked and pitted and creviced and boiling, rarely white, rarely of a single hue, but infinitely varied shades of gray, dark-gray, powder-gray, bruise-gray, iron-gray, purple gray, shot with a**

**mysteriously advancing, and abruptly fading, sunlight. Rain was falling, or had recently fallen leaving everything slick, wet, shining, washed-clean; sullen, punished-looking; or gleaming with optimism, hope.”**

**Joyce Carol Oates (b. 1938)  
Upstate’s Novelist**

**“I have always loved to use fear, to take it and comprehend it and make it work and consolidate a situation where I was afraid and take it whole and work from there.”**

**Shirley Jackson (1916-1965)  
Master of Gothic Fantasy and Fiction**

## **SYRACUSE WRITERS AND THEIR WORDS**

**I never saw any colored person in any position of authority in Syracuse until the U.S. Army held maneuvers in the area around 1909, and several companies of Negro soldiers were camped in a large park where traveling circuses usually performed. The black infantrymen and cavalrymen were something else again. We were impressed by their superb order and discipline,**

**their haughty and immaculate noncommissioned officers, and their obvious authority. The only colored men in uniform that we had seen were our fathers in the uniforms of the Knights of Pythias and the Odd Fellows, and they were simply ludicrous, representing nothing.**

**George Schuyler (1895-1977)  
Satiric Writer of the Harlem Renaissance and a  
Voice of Black Conservatism**

**“An old man, crippled and torn  
Came to us looking for bread and corn  
He was unsightly and needed some care  
Nobody helped him, no one dared  
Wolf, turtle or bear? Who gave him food?  
Who clothed his back? A bear woman was  
good  
Little light, both day and night  
Took care of the old man all day and night”**

**Joanne Shenandoah (b. 1958)  
Musical voice of the Haudenosaunee**

**“First thing you learn  
is that you’ve always got to  
wait.”**

**Lou Reed (1942-2013)  
Rock and Roll Animal**

**“Ashamed, people turned their faces away  
from the woman ranting, asking: Justice,  
stretch out your hand. Come down,  
glittering,  
from where you have hidden yourself  
away.”**

**Minnie Bruce Price (b. 1946)  
Poet and Lesbian activist**

**“There are weapons that are simply  
thoughts, attitudes, and prejudices,  
to be found only in the minds of  
men. For the record, prejudices can  
kill and suspicion can destroy ... The  
pity of it is, these things cannot be  
confined to the Twilight Zone.”**

**Rod Serling (1924-1974)  
You are entering the Twilight Zone**

# SYRACUSE WRITERS AND THEIR WORDS

“But the Ward was not always black and it was not always unhappy. Many kinds of people lived there, Negroes, Jews, Italians, Irish, Poles, Indians and “native Americans.” The people shared conversation and other small joys. The religious holidays of all were greatly respected. If your parents were at work or shopping someone on the block had his or her eye on you. In the Ward survival of the other

fellow and his children meant survival for you. For me, the Ward was home and the rest of Syracuse radiated outward from it. It was a city within a city and at dusk the year around, you could see men of all sizes, shapes and colors returning to it from their jobs, such as they were.”

John Williams (1925 – 2015)  
Writer of the *Second Harlem Renaissance*;  
Raised in Syracuse’s 15th Ward

“So we beat on, boats against  
the current, borne back  
ceaselessly into the past.”

F. Scott Fitzgerald (1896-1940)  
America’s Novelist

Freight train, freight train, going so fast  
Freight train, freight train, going so fast  
Please don't tell what train I'm on  
So they won't know where I'm gone.

Freight train, freight train, going round  
the bend  
Freight train, freight train, gone again  
One of these days turn that train around

Elizabeth Cotten (1893 – 1987)  
Grandmother of the Blues

“That proves you are unusual,”  
returned the Scarecrow; “and I am  
convinced that the only people  
worthy of consideration in this  
world are the unusual ones. For the  
common folks are like the leaves of  
a tree, and live and die unnoticed.”

L. Frank Baum (1856-1919)  
America's first fantasy writer, author of the  
book “The Wonderful Wizard of Oz”

## SYRACUSE WRITERS AND THEIR WORDS

“These narratives are an attempt to fill  
my body and soul. To seduce myself,  
lick my own heart, gather memories  
like flowers and fireflies, bring every  
piece of me to the bedroom of my skin  
and not be afraid of love - even now.  
Even now.”

Safiya Henderson-Holmes (1950-2001)  
A soulful poet writing through adversity



# SYRACUSE WRITERS AND THEIR WORDS

240'

Original Fence

REMOVE LOWER PANELS AND USE TO REPLACE DAMAGED PANELS

Installation Color Gradient

Installation 1 Layout

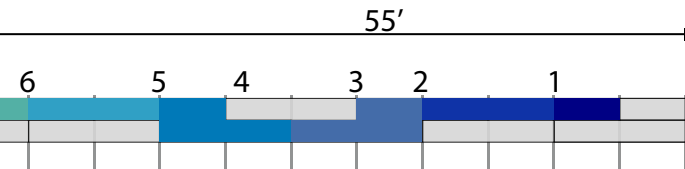

Freight train, freight train, going so fast  
Freight train, freight train, going so fast  
Please don't let what train I'm on  
So they won't know where I'm going.

"That proves you are unusual,"  
returned the Scarecrow, "and I am  
convinced that the odd people  
worthy of consideration in this  
world are the unusual ones. For the  
common folk are like the leaves of  
a tree, and live and die unnoted."

L. Frank Baum (1856-1919)  
Author's first fantasy writer, author of the  
book "The Wonderful Wizard of Oz"

**SYRACUSE WRITERS  
AND THEIR WORDS**

"These narratives are an attempt to fill  
my body and soul. To welcome myself,  
but my own and gather memories.  
like flowers and fireflies, bring every  
piece of me to the bedrock of my skin  
and out by afraid of love - even now.  
Drops rain."

Sally Henderson-Jones (1910-2012)  
A middle-aged woman through adversity

"But the West was not always black  
and it was not always solitary. Many  
kinds of people lived there, Anglos,  
Jews, Italians, Irish, Poles, Indians  
and "native Americans." The people  
shared conversation and other small  
joys. The religious holidays of all were  
greatly respected. If your parents  
were at work or shopping someone  
on the block had his or her eye on  
you. In the West survival of the other  
fellow and his children meant survival  
for you. For me, the West was home  
and the rest of Syracuse refused  
outward from it. It was a city within a  
city and at dusk the year around, you  
could see men of all sizes, shapes  
and colors returning to it from their  
jobs, such as they were.

John Winters (1917 - 2012)  
Writer of the  
Raccoon Harbor (Huntsville)  
Based in Syracuse, N. York West

"So we beat on, boats against  
the current, borne back  
ceaselessly into the past."

F. Scott Fitzgerald (1896-1940)  
Author's Novels

"Because we want the peace  
with half a heart and half a life  
and will, the war, of course,  
continues, because the waging  
of war, by its nature, is total - but  
the waging of peace, by our own  
cowardice, is partial."

Neil M. Williams (b. 1911)  
Model-Landmark who single-handedly  
as single author to Syracuse

Donald Serfaty (1913-2019)  
Poet, poet and peace and human rights  
activist

"So often, the Syracuse sky was  
overcast and gloaming, as if with  
withheld secrets, passions. Clouds  
were never two-dimensional like  
painted scenery but massed,  
massive, bulging, tumescent, puffed  
and jittered and creased and billowing  
rarely white, rarely of a single hue,  
but arbitrary varied shades of gray,  
dark-gray, powder-gray, bruise-gray,  
iron-gray, people gray, shot with a  
mysteriously advancing, and abruptly  
fading, sunlight. Rain was falling, or  
had recently fallen leaving everything  
slick, wet, shining, washed-clean  
shines, polished-looking, or gleaming  
with optimism, hope."

Joseph Conrad (1857-1924)  
Upstart's Novels

"My neighbors! I have lived with you  
many years, and you know me. My  
house is here, and my children were  
born here. I am bound to Syracuse by  
peculiar interests, and social and  
family bonds. And do you think I can  
be taken away from you and from my  
wife and children, and be a slave in  
"Surrender?"

Harriet Ann Jacobs (1815-1892)  
Born with a burden of oppression

"Do not allow the Church or  
State to govern your thought  
or dictate your judgment."

William Augustus Dyer (1826-1902)  
Born with a burden of oppression

"Writers don't need tricks or  
genetics or even necessarily need  
to be the smartest fellows on the  
block. At the risk of appearing  
facetious, a writer sometimes needs  
to be able to just stand and gape  
at this or that thing - a sunset or an  
old shoe - in absolute and simple  
amazement."

Raymond Carver (1939-1982)  
Master of the Short Story

**SYRACUSE WRITERS  
AND THEIR WORDS**

Many authors, poets, and writers who have  
of the important contributions to the world  
have made Syracuse by their words.  
Let's celebrate their lives, acknowledge  
our diversity and remember the words of our  
writers, past and present.

\*Started in 2015, this ongoing installation will  
add panels to the fence over time.

"An old man, stooped and thin  
Came to us looking for bread and care  
He was unshiny and needed some care  
Nobody helped him, no one cared.

"First thing you learn  
is that you've always got to  
wait."

Law Reed (1940-2019)  
Rock and Roll Artist

"Ashamed, people turned their faces away  
from the women crying, asking, justice,  
stretch out your hand. Come down,  
give us.  
From where you have hidden yourself  
away."

White Snake Price (b. 1940)  
Poet and Lecturer (NYC)

"There are weapons that are simply  
thoughts, attitudes, and prejudices,  
to be feared only in the minds of  
men. For the record, prejudices can  
kill and suspicion can destroy... The  
pity of it is, these things cannot be  
confined to the "Hellfire Club."

Red Kelley (1920-1974)  
Poet and Lecturer (NYC)

"I have always loved to use fear, to  
take it and compound it and make  
it work and consolidate a situation  
where I was afraid and take it whole  
and work from there."

Samuel Johnson (1709-1850)  
Master of Gothic Fantasy and Fiction

**SYRACUSE WRITERS  
AND THEIR WORDS**

I never saw any colored person  
in any position of authority in  
Syracuse until the U.S. Army held  
maneuvers in the area around 1900,  
and several companies of Negro  
soldiers were camped in a large park  
where traveling chessmen usually  
performed. The black infantrymen  
and cavalrymen were something  
else again. We were impressed by  
their superb order and discipline,  
their haughty and immaculate  
noncommissioned officers, and their  
obvious authority. The only colored  
man in uniform that we had seen  
were our fathers in the uniforms  
of the Knights of Pythias and the  
Odd Fellows, and they were simply  
business, not anything exciting.

George Schuyler (1865-1917)  
Author, Master of the English Renaissance and a  
Slave of Black Consciousness

Installation 1 Layout - ENLARGED

# LOCUS

## DESIGN GROUP

LOCUS AMPLIFIES THE PURPOSE OF ORGANIZATIONS AND ELEVATES THE ASPIRATIONS OF CITIES THROUGH URBAN DESIGN, PRACTICE BUILDING, AND PLACE MAKING.

**WE BELIEVE IN THE IMPORTANCE OF WELL-CRAFTED, APPROACHABLE, AND MEMORABLE DESIGN SOLUTIONS THAT ARE PRAGMATIC, SOCIALLY AND ECOLOGICALLY INTEGRATIVE.**

We are committed to the design of vibrant and productive spaces and to communicating ideas with clarity, rigor and style. We are invested in collaboration as a means to create positive social, cultural, and economic impacts by building teams of collaborators, experts and community stakeholders who work together from the beginning of the project. We believe that the public should be proud of their common spaces and eager to spend time in them together.

**WE ARE A BRANDING GROUP TAILORED TO THE DESIGN AND DEVELOPMENT INDUSTRIES.**

Our team of designers and communicators has deep expertise in the planning, architecture, landscape architecture, design and development industries. This background gives us inherent insights into the means and methods of your work and a unique understanding of how to communicate industry jargon. We understand how you think, because its how we think too.

We guide our clients through the process of telling their story and adding value to their brand by constructing a legible organizational identity, curating marketing materials, or developing their new website.

**WE ARE A DESIGN FIRM DRIVEN TO ELEVATE AND COMMUNICATE SPECULATIVE AMBITIONS.**

We selectively partner with planning and development professionals to design award winning public spaces, create progressive master plans, and envision unique development concepts. We love the challenge of working on high impact projects whose success is tied to how well the idea connects with people.

We understand the power of a legible idea, a bold identity, and clear communication. We bake that way of thinking right into the design process so that our clients can always be armed with the resources they need to advance their project.

LEARN MORE AT [www.designinglocus.com](http://www.designinglocus.com)



**JOE SISKO**  
**MANAGING PARTNER**

Joe is an urban designer, architectural educator, and brand creator who leverages visual communication to facilitate positive and sustainable organizational growth or community impact. He is responsible for the firm management, overall strategic goals and creative direction. He teaches urban design, advanced media, and architecture at the undergraduate and graduate levels as an adjunct professor of architecture at the Syracuse University School of Architecture. Prior to founding LOCUS he was the Assistant Director of UPSTATE: at the Syracuse University SOA where he initiated and managed the institute's public space, master planning and research projects from public engagement through concept design and implementation.

**PROJECT EXPERIENCE**

***branding (selected)***

- Syracuse Surge, Brand/Graphics
- Salt City Market, Brand
- Ashley McGraw, Brand/Web
- Greater Syracuse Hope, Web
- Dietz Lofts, Brand/Web/Design
- Doyle Lofts, Brand/web
- AnSCO Lofts, Brand/Web/Design

***design (selected)***

- Salina Park
- Performance Park
- Elevating Erie, Masterplan
- Elevating Erie, Public Space
- 307 E Division St
- Albany BID STEAM Garden Center
- SMART Logistiport
- Onondaga Creek Masterplan
- Riverwalk Village Masterplan
- Dineen Hall: Land and streetscape
- Forman Park
- Warehouse Park
- Case Supply site
- Otisco Street Green Infrastructure
- Connective Corridor
- Syracuse Stage Plaza
- Civic Strip
- Near West Side Master Plan
- Archiving Syracuse
- Rethink 81 To Reclaim the City and Reconnect Syracuse

***competition management***

- Elevating Erie
- From the Ground up
- Freedom's Gate
- Urban Rest Stop
- Movement on Main

**EDUCATION**

Masters of Architecture II (Magna Cum Laude) Syracuse University  
 Bachelors of Architecture (Magna Cum Laude), Kent State University  
 Bachelors of Science (Cum Laude), Kent State University

**PROFESSIONAL EXPERIENCE**

Locus Design Group, LLC. Founding Partner	2015 - present
Commonspace Properties, Inc. Partner	2019 - present
UPSTATE: Assistant Director	2008 - 2014
SU School of Architecture. Adjunct Professor	2008 - ongoing
Ashley McGraw Architects. Architectural Designer	2007 - 2008
Dorsky Hodgson Parrish Yue. Arch Designer	2005 - 2006
KA. Architectural Designer	2005- 2006

**SELECTED PUBLICATIONS, AWARDS, HONORS**

- "Role of Infrastructure in the history and future of Legacy Cities" paper presentation, Bruner Loeb National Design Forum
- "Bold Experiments" paper presentation, Imagine America National Conference
- "American City X- After the Masterplan" Princeton Arch Press, contributing project on Onondaga Creek
- "Urban Intervention" in Metropolis Interviewed for an article by Steven Zacks.
- "Urban Instrumentation" paper presentation, Imagine America National Conference
- "Home Turf" - Faculty Works Exhibition at Syracuse School of Architecture
- "L-DOT" - Exhibition for responsive building skin research at Greenbuild, Boston
- AIA Design for Aging: Merit Award, Research
- 'Assessing the Impact of Daylight and Natural Views' featured at the 2007 AAHSA Conference and AIA National Convention
- "How Building Form Affects Energy" paper presentation, Onondaga County Convention Center, Green Build
- Editor, SUSOA Seminar Discussions\_ Transdisciplinary Applications
- "Urban Linguistics" Exhibition/ installation at Syracuse Architecture, Warehouse



**TREVOR LEE**  
**PARTNER**

Trevor Lee is a landscape architect, artist, and graphic designer with urban planning and visual communications expertise. As an Associate at James Corner Field Operations, he led the concept phase of The High Line section 3 and the winning competition entry for Chicago's Navy Pier. He teaches studios at the Illinois Institute of Technology and the University of Pennsylvania and has led studios at Syracuse University. Trevor has worked with Michael Singer, OLIN and Martha Schwartz Partners. His work with LOCUS focuses on the development of public space, urban design and visual and branding identities.

**PROJECT EXPERIENCE**

- Land Art Generator Initiative
- Windnest- Installation
- High Line Section 3
- Salina Park
- Chicago Navy Pier Competition
- Tsim Tsha Tsui Waterfront
- Philadelphia Navy Yard
- Performance Park
- Elevating Erie
- Syracuse Writers
- Dietz Lantern Factory Lofts
- Dineen Hall
- Near West Side Neighborhood
- Syracuse Stage
- Jeju Games, Gardens
- Jardin De Metis
- The Green Single

**PUBLICATIONS**

- UPENN Landscape
- Water Infrastructure: Equitable Development
- M3 Magazine
- Orion Magazine
- Planning and Design for Future Informal Settlements
- Shawati' Magazine "Globalizing the Local, Localizing the Global,"
- Land Art Generator
- Landscape Infrastructure
- Reinventing Grand Army Plaza
- UPENN Landscape
- OLIN Monograph
- LAM
- Mark Magazine
- Garten + Landschaft
- Urbanite Magazine
- Casabella Magazine
- RISD Catalog

**EDUCATION**

MLA, Landscape Architecture, Rhode Island School of Design  
BFA, Illustration, Massachusetts College of Art

**LICENSURE**

Ohio Landscape Architecture Board  
Certificate No. LA. 1601371

**PROFESSIONAL EXPERIENCE**

Locus Design Group, Partner	2015 - present
Illinois Institute of Technology, Visiting Asst. Prof	2017 - 2019
Suprafutures, Principal	2013 - Current
University of Pennsylvania, Lecturer	2007 - Current
James Corner Field Operations, Associate	2011 - 2013
UPSTATE: Design Fellow	2009 - 2011
OLIN, Senior LA Designer	2005 - 2009
Martha Schwartz, Landscape Designer	2003 - 2005
Michael Singer, Consultant	2001 - 2007
L+A, Senior LA Designer	2002 - 2003
Mik Young Kim Design, Consultant	2001

**AWARDS + HONORS**

- Yale University's Kroon Hall School of Forestry and Environmental Studies  
SBIC Beyond Green High Performance Building, Citation Award 2010
- Smithsonian's Cooper-Hewitt National Design Award for Landscape Design, OLIN 2008
- American Society of Landscape Architects Firm Award, OLIN 2008
- Merit Award, RI ASLA, 'Arboreal Infrastructure Initiative' Analysis and Planning, Providence, RI 2005
- Art School Associates Floyd Covert Scholarship, 1997